

# **The City of Girard**

## **Water Distribution Department**



### **Backflow**

## **Prevention/Cross-Connection Control**

## **Program Manual**

**PWS ID Number: OH7801103**

**Population Served 15,000**

**First Edition-2020**

**Manual  
Of  
Backflow Prevention  
And  
Cross-Connection Control  
Program**

The City of Girard  
100 West Main Street  
Girard, Ohio, 44420

First Edition  
Edited by Michael T. Scoville  
Backflow Coordinator

## PREFACE TO THE FIRST EDITION

This manual was designed to follow good engineering practices for the protection of the City of Girard's potable water system from contamination by backflow. It was specifically written for the use in The City of Girard, Ohio, in which the City of Girard Backflow Ordinance, the Department of Commerce Code, The Ohio Administrative Code, and the Ohio EPA Rules and Regulations, were used for best practice purposes when referring to the laws pertinent to the controlling of proper protection of the City of Girard's potable water supply and system.

This manual is also intended for use as a self-training manual for water supply personnel and others involved in cross-connection control. Although this manual discusses all aspects of backflow prevention and cross-connection control, its main emphasis is promoting the City of Girard's mission along with the Ohio EPA's rules and regulations in protecting the City of Girard potable water supply. This manual was designed based off of the Ohio EPA Manual for Backflow Prevention and Cross-Connection Control Fifth Edition and Operators Training Committee of Ohio Backflow Prevention Student Manual with the permission of the said entities.



**CITY OF GIRARD**  
**WATER DISTRIBUTION**  
**Backflow Program**

**Acknowledgement and Guidelines for Certified Testers**

Water Supply Backflow Program for: City of Girard

PWSID: OH7801103 County: Trumbull

Population Served: 15,000 Date: 8/10/2020

The City of Girard has created this backflow program for the protection of its public water supply and its consumers. This program shall be followed by all public water supply users, certified backflow prevention testers, certified plumbers and the City of Girard water department for the testing, installation and inspection of all backflow prevention devices installed within the City of Girard's water supply system.

This program shall be evaluated annually to ensure all the proper safety rules and appropriate backflow prevention devices are incorporated into the program.

All commercial businesses purchasing water from the City of Girard Water Department shall have installed an appropriate backflow prevention device. The type of device required is based off of what danger your company imposes upon the water system.

All certified testers shall submit all renewals of their credentials to test when they expire as well as submit their annual certification letter of the calibration of the testing equipment used. All testing equipment shall be calibrated yearly and all documentation sent to the City of Girard upon receipt of the said certification letter.

All newly installed Backflow Preventers must be inspected and approved by the City of Girard Backflow Prevention Coordinator.

All certified testers shall use only approved testing sheets which will be sent to the customer's location along with an annual letter that is sent to the consumer/owner of the backflow prevention device. Each location tested shall have a tag which will be supplied by the City of Girard attached to the devices tested and all information must be filled out during testing, unless said tester already has tags, if more tags are needed please contact the City of Girard Water Department.

Any certified tester that fails to notify the City of Girard of any consumers backflow prevention device failures, or has not sent a copy of their renewals or calibration certificates will be removed from the approved certified testers list which will be posted on the City of Girard's website until all said documentation is provided, non-reported failures will cause permanent removal from approved list.

All test documents shall be sent via email or through the mail. No more faxes will be accepted. All test documents must be legible, if they are not, a request for a legible copy will be sent to the tester.

Only fire and containment testing documents will be accepted by the City of Girard. The City of Girard is not responsible for any isolation device records and will not accept any isolation test documents.

A copy of the City of Girard backflow program can be found on the City of Girard's website under the Water tab. [www.cityofgirard.com](http://www.cityofgirard.com).

If more testing sheets are needed for a consumer location, they can be found at the City of Girard website under water tab. A list of all approved backflow devices can be found in the City of Girard backflow program manual, which can be found at the City of Girard website under the water tab.

All portions of this program were created to meet the requirements of the Ohio EPA backflow program, the Ohio Revised Code, the Ohio Department of Commerce and the City of Girard Water Distribution System. All content used for this program is credited in Appendix I of this manual.

If there are any questions or concerns about this program, please contact the City of Girard water department and they will direct you to the appropriate contact person to assist you.

This program has been approved and accepted by the following on this said day of August 10, 2020.

City of Girard Safety/Service Director: Jerome Lambert

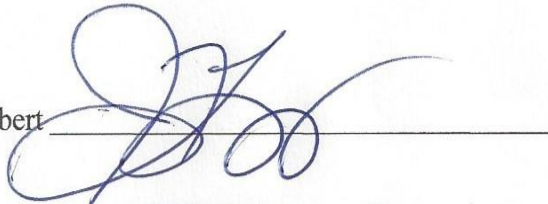

Water/Waste Water Superintendent: Howard Zickefoose



Backflow Prevention Coordinator: Michael Scoville



**CITY OF GIRARD**  
**DRINKING WATER SUPPLY**  
**Backflow Program**  
**Revision Sheet**

Water Supply Backflow Program for: City of Girard

PWSID: OH7801103 County: Trumbull

Population Served: 15,000 Date: 6/17/2020

**REVISIONS:**

(All copies of this plan must be revised as changes in the water supply system backflow program and accepted list of Certified Testers are made. If none of these occur, then the plan must be reviewed and updated at least annually.)

<b>Page</b>	<b>Section Revised</b>	<b>Date</b>	<b>Revised By</b>
All	Entire Program	6/17/2020	Michael T. Scoville

# Table of Contents

<b>I. Backflow Prevention and Cross-Connections</b>	1
<b>Section 1. Why the Need for Backflow and Cross-Connection Control</b>	1
<b>Section 2. What is a Cross-Connection</b>	4
<b>Section 3. Backpressure</b>	5
<b>Section 4. Backsiphonage</b>	6
<b>Section 5. Containment</b>	7
<b>Section 6. Theory</b>	9
<b>II. Rules and Regulations on Backflow Prevention and Cross-Connection Control</b>	12
<b>Section 1. Cross-Connection Control-General Policy</b>	12
<b>Section 2. Definitions</b>	14
<b>Section 3. Installation of Devices</b>	18
<b>Section 4. Backflow Prevention Devices</b>	20
<b>Section 5. Water System</b>	22
<b>Section 6. Cross-Connection Prohibited</b>	23
<b>Section 7. Survey and Investigations</b>	24
<b>Section 8. Where Protection is Required</b>	25
<b>Section 9. General</b>	27
<b>Section 10. Types of Protection Required</b>	29
<b>Section 11. Backflow Preventers</b>	31
<b>Section 12. Certified Testers</b>	32
<b>Section 13. Backflow Prevention Assembly Maintenance and Testing</b>	34
<b>Section 14. Booster Pumps</b>	35
<b>Section 15. Fire Protection</b>	36
<b>Section 16. Other Hazard</b>	38



<b>Section 17. Evaluating Degree of Hazard</b>	.....46
<b>Section 18. Responsibility &amp; Authority</b>	.....61
<b>Section 19. Inspection, Testing, and Maintenance</b>	
<b>Procedures for Backflow Preventers</b>	.....66
<b>Section 20. Written Notification</b>	.....130
<b>APPENDIX A: OEPA-PWS-02-000</b>	.....142
<b>APPENDIX B: Ohio Laws &amp; Rules Pertaining to</b>	
<b>Backflow Prevention and Cross-Connections</b>	.....148
<b>APPENDIX C: ORC Chapter 3145-95</b>	.....153
<b>APPENDIX D: Ohio DOC Rules &amp; Regulations</b>	.....171
<b>APPENDIX E: ORC 37545-10 Abandoned Well</b>	
<b>Sealing</b>	.....197
<b>APPENDIX F: ORC 3701-28-17 Procedure for the</b>	
<b>Sealing and Decommissioning of Private Water</b>	
<b>Systems</b>	.....202
<b>APPENDIX G: City of Girard Ordinance 6191-90</b>	.....211
<b>APPENDIX H: Instructions for Completing Annual</b>	
<b>Surveys for Auxiliary Water Systems</b>	.....213
<b>APPENDIX I: Approved Certified Testers List</b>	.....215
<b>APPENDIX J: Bibliography</b>	.....217

*This page left intentionally blank*

# **I. Backflow Prevention and Cross-Connections**

## **Section 1.**

### **Why the Need for Backflow Prevention and Cross-Connection Control**

- A.** Backflow can be described as “A reversal of the normal direction of flow within a piping system”, or as “the flow of water or other liquids, mixtures or substances into the distribution pipes of a potable water supply from any source other than the intended source of the potable water supply.
- B.** The potential for a backflow condition occurring in a user’s water system is all too likely. In many of our homes, factories and public buildings, there may be cross-connections that can, under backflow conditions, introduce a liquid, mixture or substance into the user’s or public water system.
- C.** The probability of backflow taking place at any given outlet may actually be very small. But, in view of the large number of possible connections, the probability over all becomes very significant and must be dealt with in a positive way.
- D.** The universal acceptance of public water systems as being safe can lull us into complacency with a feeling that all the work in the area has been completed and that our water systems have reached the ultimate in safety. This is not true.
- E.** It is necessary to continue the surveillance of these systems in order to maintain the level that has been reached and we must work even harder to improve these present supplies.
- F.** Because of potential backflow from water-flushed sewage systems, such as the drinking water that is provided at sinks, toilets, bathtubs, and similar plumbing fixtures, it is obvious that in order to prevent the contamination of the public water system such a fixture must be designed and installed in such a way that flow can be only in direction intended.
- G.** Plumbing codes are written to protect our health by protecting our drinking water.
- H.** Those who are not familiar with cross-connection control or backflow prevention can quickly and easily convert a safe water supply into an

unprotected or Insafe supply without realizing that a hazard has been created.

- I.** These hazards may manifest themselves immediately after they have been created or they may lie dormant for a long time until the right chain of circumstances triggers a disastrous situation.
- J.** In addition to sewage backflow, many other possible hazards exist. Pressurized systems carrying impure process water, caustics, acids, fertilizer, or other hazardous substances can be connected to the drinking water supply through aspirators or pumping devices.
- K.** Dual water supplies for the fire control systems can also create hazard. Homeowners, previously served by private wells who have since tied into a public water system, may find it difficult to abandon their wells because of the money invested.
- L.** Such cross-connections between an individual water supply of unknown quality and a public water system creates a potential hazard to the public water system.
- M.** Two basic types of backflow exist. One is caused by cross-connection of a public water system with another pressurized system.
- N.** The other is caused by a vacuum from siphon action. It is obvious that when a second system will be forced into the public water system.
- O.** A closed valve or check valve in the system cannot be relied upon to stop this flow. Valves are not watertight 100% of the time. Valves can develop leaks due to normal wear. A leaky valve may pose a risk to human health.
- P.** The hazard created by a cross-connection between two pressurized systems is compounded when the pressure in the public water system drops. The problem is further aggravated if the public water system develops a vacuum.
- Q.** Many circumstances can cause a drop in pressure or the development of a vacuum in a pressurized water system and these conditions do develop, periodically and unexpectedly.

- R.** A vacuum condition may develop in portions of a distribution system by a high-volume water use or by a broken water main or an open fire hydrant. These vacuum conditions not only compound the problems between pressure systems, but also may contaminate systems by allowing flow through any unprotected opening connected to the public water supply. Common examples include hose bibs or threaded faucets where a hose is attached.
- S.** Many hazards can be found in industrial plants, factories, schools, hospitals, or any location that is served by a public water system.

## Section 2.

### **What is a Cross-Connection?**

- A.** cross-connection can be described as “any arrangement whereby backflow can occur, or as any arrangement of pipes, fittings, fixtures, or devices that connects a non-potable water system to a potable water system.
  
- B.** It is the point at which a water-using fixture is connected to the user’s water system. An unprotected cross-connection provides the path or route through which backflow can occur.
  
- C.** It can be:
  - 1. Permanent or temporary
  - 2. Actual or potential
  - 3. Direct (subject to backpressure & back siphonage) such as a boiler or indirect (subject to back siphonage only) such as toilet tank fill valve.
  
- D.** Some of the more common examples are:
  - 1. Boiler make-up lines
  - 2. Chiller make-up lines
  - 3. Fire protection systems
  - 4. Spray hoses
  - 5. Suction tees or aspirators
  - 6. Tanks or vats with a submerged inlet
  - 7. X-rays & photo developing equipment
  - 8. Irrigation systems
  - 9. Hand-held lawn sprayers
  - 10. Pressure washers
  - 11. Commercial grade dishwashers
  - 12. Commercial grade garbage disposals or grinders
  - 13. Soap, sanitizer or wax education systems
  - 14. A janitor’s sink with a hose attached
  - 15. Hose bibs with a garden hose attached
  - 16. Toilet tanks

### **Section 3.**

#### **Backpressure**

- A.** Backpressure can be described as a reversal of the normal direction of flow in a piping system due to a downstream pressure that is greater than the supply pressure.
- B.** When the pressure is greater in a water user's system than the pressure in the public water system, the water will reverse its normal direction of flow and flow towards the public water system.
- C.** Backpressure can be created by boilers, chillers, internal pumping systems, or any other system, the water pressure that is greater than the normal supply pressure.
- D.** So, if a fixture, such as a boiler, creates a pressure greater than the supply pressure then there will be backflow unless the appropriate backflow prevention device is installed and working properly.
- E.** Pumps on secondary or auxiliary water system installations are primary cause of back pressure and can be found at a variety of premises.
- F.** A typical backflow situation involving pumps is illustrated by visualizing a pump supplying well water to a plumbing system that is also connected to the public water supply. If the pump is capable of producing a higher pressure than the public water system or if the public water system pressure should drop, then the pump can discharge its water through the internal plumbing system into the public water main.
- G.** Often factories or commercial buildings have a secondary or auxiliary water system for fire protection or process systems. If the auxiliary water system has an unprotected cross-connection with the public water system then a potential hazardous backflow situation can be created.

## **Section 4.**

### **Backsiphonage**

- A.** Backsiphonage can be described as a reversal of the normal direction of flow in a piping system due to drop in the supply pressure to the point where a vacuum, partial vacuum or negative pressure occurs in the upstream piping.
  - 1. A vacuum is defined as any point in the water system where the pressure is less than the prevailing atmospheric pressure (14.7 psi at sea level).
- B.** A drop in the supply pressure in the water main or in the water user's internal piping will cause a reversal of the flow in that piping due to backsiphonage.
- C.** Generally, backsiphonage occurs more frequently in the water user's system in the building and primarily on the upper floors than to the public water system since the volume or duration of a backsiphonage condition is usually not of sufficient quantity or duration to reach the public water system. It can be caused by insufficient internal hydraulic capacity or by a drop in pressure in the supply or upstream piping.
- D.** Backsiphonage can be caused by a water main break, by a break in the water user's piping, if the water main is turned off for maintenance or repair, if a fire hydrant is struck, if the fire department is drawing water to fight a fire, or by an abnormally heavy water demand on the water main.



## Section 5.

### **Containment**

- A.** The installation of an approved backflow prevention assembly on the consumer's service connection to protect the public water system from a possible contamination is known as containment. Experience has shown that it is physically and economically difficult to locate and eliminate permanently all cross-connections within many consumer's water systems.
- B.** For an outsider to make a thorough and complete survey of piping within the larger and more complicated industrial plants is almost impossible.
- C.** Many cross-connections are hidden within various kinds of water-using equipment, in walls, underground or in other temporary connection may be submerged in a hazardous material only for short periods of time and be, missed during an inspection.
- D.** Piping systems in industrial plants are constantly being revised as new products and production methods are developed. Piping or equipment changes are frequently made, usually without authorized inspection, and may result in the creation on new cross-connections.
- E.** Therefore, in addition to an effective program for new plumbing installations, bolstered by periodic surveys to address any changes in water use practices, an additional defense is needed to protect containments from backflowing into the public water system.
- F.** This may be accomplished by a procedure known as "control by containment" which involves the installation of a backflow prevention assembly on the consumer's supply line.
- G.** Such an installation may be required by the supplier of water when, in the opinion of the supplier of water, additional protection to the public water supply system is required.
- H.** Certain types of facilities are required by rule to install such containment backflow prevention assemblies on the service connection. The use of such an assembly does not eliminate the requirements for individual fixture devices or "air gaps" which isolate the cross-connection at the possible

source of contamination or the consumer's responsibility to prevent the installation of illegal cross-connections.

- I.** An evaluation of water use practices at a facility, as well as the isolation devices in place, are integral in determining the level of protection and type of backflow preventer necessary for containment purposes.
- J.** While the installation of a backflow prevention assembly on the consumer's service line will protect the public water system, it will not protect those persons within the plant or building who drink water.
- K.** To protect those persons within the plant or building, the containment concept can be utilized within the consumer's water system by isolating portions of the plumbing.
- L.** The consumer may install a backflow prevention device on the water leading to those portions of his/her plant or building where there are actual or potential hazards to the potable water supply.
- M.** In some large plants, devices might be installed on several such branches. The concept of containment within a plant or building is very important since, in a large installation, several thousand people might be employed.
- N.** Installation of a device to address a cross-connection at the point of possible contamination within the plumbing is referred to as an isolation device.
- O.** The following section explains the roles and responsibilities of the parties involved. It is also providing the framework of the rules and regulations that apply for backflow prevention and cross-connection control from the water treatment plant to the consumer's tap.

## Section 6.

### Theory

#### **A. Upstream Versus Downstream**

1. Upstream refers to the supply side (watermain side) of any appurtenance connected to the water supply system.
2. Downstream refers to the discharge side (water user's side) of any appurtenance connected to the water supply system.

#### **B. Atmospheric Pressure**

1. The air surrounding the earth has a weight sufficient to exert pressure of 14.7 pounds per square inch at sea level. This atmospheric pressure is equivalent to the pressure exerted by a column of water 34 feet high.

#### **C. Head Pressure & Elevation Head**

1. Head pressure is the force, usually from a pump, that pushes the water forward. It takes one pound of pressure to lift a column of water 2.31' or 28" high. The pressure is diminished by frictional loss as the water travels through the pipe or a fixture, but these losses are usually minimal.
  - a. So to lift the water through the consumer's piping to the second floor would cause a loss of 1 pound of pressure for every 2.31' or 28" high that the water has to be elevated.
  - b. Water pressure minus (elevation/2.31') = pounds of water pressure lost to lift the water in the piping where; Water pressure is at 60 psig; elevation is 11.5';  $60 \text{ psig} - (11.5'/2.31') = 55 \text{ psig}$  on the second floor.
2. Elevation head is the force of the weight of the water in the piping. A column of water 1' high has a pressure at its base of 0.433 psig. If you put another 1' column of water on top of the first column, the pressure at the base is now 0.866. Each additional 1' column of water adds an additional 0.433 psig pressure at the base.

#### **D. Vacuum**

1. A vacuum can be described as any location in a water system where the pressure in the piping system is less than the prevailing atmospheric pressure.
2. Since atmospheric pressure is 14.7 pounds per square inch, if the pressure in the public water system drops below 14.7 psi then

backsiphonage will result when atmospheric pressure enters the water user's piping system through an internal fixture.

3. If there is a pressure less than atmospheric in the water main, the atmospheric pressure will push the water from the tanks toward the public water system. It may not get into the water main but there is the probability that the other fixtures in the building will be contaminated.
4. The reason that you are required to maintain a minimum of 20 psig in the water main is to provide a margin of safety above the point of a vacuum or 14.7 psi. Failure to do results in the need to issue "boil water advisory" which means that the conditions were right for backsiphonage to have occurred.
5. A complete or total vacuum means a pressure of 0 psia or psig. Since it is nearly impossible to produce a total vacuum, for purposes of this course, the term vacuum will mean all degrees of partial vacuum.

### **E. Venturi Principle**

1. One of the basic principles of fluid mechanics is the principle of fluid motion. The premise of this principle is that as a fluid flows through a constriction in the piping, its velocity increases which reduces the pressure at the constriction; thereby creating a siphon at the constriction. Using this principle, a fluid may be added to the water using only atmospheric pressure.
2. This apparatus may be called a venturi, a suction tee, an eductor, or an aspirator. The problem with this apparatus is that if a backsiphonage should occur, then the fluid being added would also be backsiphoned.
3. You will find this principle of eduction in use at the following applications, as well as many others:
  - a. Commercial dishwashers: used to add soap, sanitizer and rinse agents.
  - b. Car washes: used to add soap and wax.
  - c. Dentist offices: often used to suction saliva from the mouth.
  - d. Butcher shops: used to add soap, sanitizer and degreaser to the hose for washing the floor.
  - e. Industry: used to siphon body fluids during embalming process.
  - f. Hospital autopsy rooms: used to siphon body fluids and other debris during autopsy.
  - g. Residential: lawn & garden sprayers.
  - h. Irrigation systems: used to add fertilizer, herbicide or insecticide.
4. A venturi is one of the more common cross-connections that you will encounter in the commercial/industrial plumbing systems. Pictured in

**Figure 1.0** below is a cross-section of the venturi in a common lawn or garden sprayer.

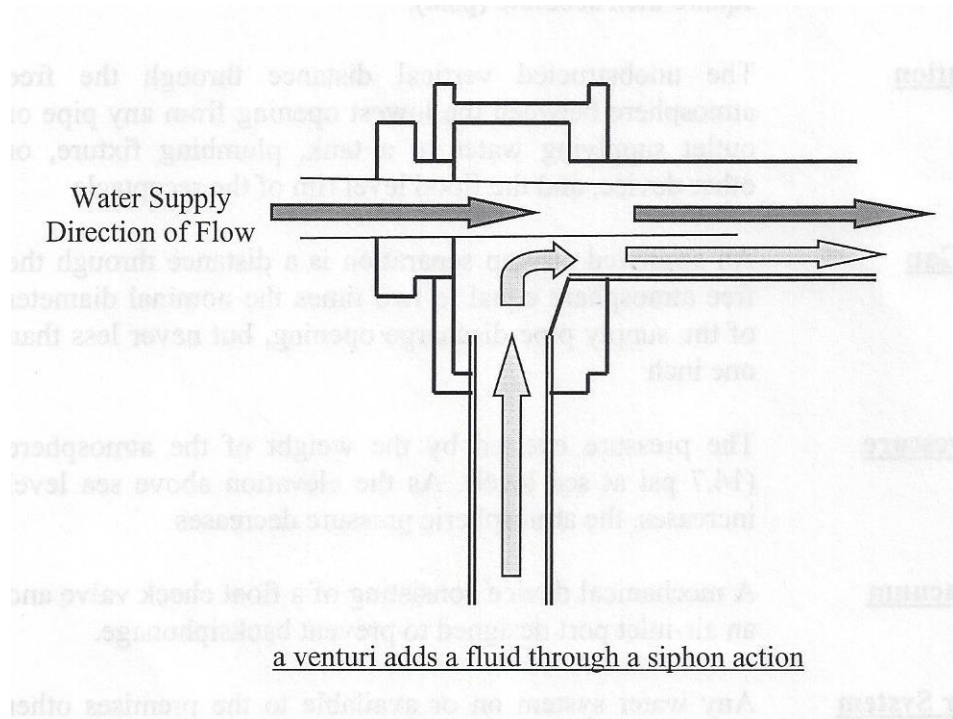

**Figure 1.0**

## **II. Rules and Regulations on Backflow Prevention and Cross-Connection Control**

### **Section 1.**

#### **Cross Connection Control – General Policy**

**A. Purpose.** The purpose of these Rules and Regulations is:

1. To protect the public potable water supply from contamination or pollution by isolating within the consumer's water system contaminants or pollutants which could backflow through the service connection into the public water system.
2. To promote the elimination or control of existing cross-connections, actual or potential, between the public or consumer's potable water system and non-potable water systems<sup>2</sup>, plumbing fixtures and sources or systems containing process fluids.
3. To provide for the maintenance of a continuing program of backflow prevention and cross-connection control which will systematically and effectively prevent the contamination or pollution of the public and consumer's potable water systems.

**B. Application.** These Rules and Regulations shall apply to all premises served by the public water system of the City of Girard, Ohio 44420.

**C. Policy.** The Safety Service Director shall be responsible for the protection of the public water system of the City of Girard, according to Ordinance 6191-90 Section 1. (**See Appendix**), from contamination due to backflow contaminants through the water service connection. If, in the judgement of the Safety Service Director, an approved backflow prevention assembly is necessary at the water service connection to a consumer's premises for the safety of the water system, the Safety Service Director or his authorized representative shall give notice to the consumer to install such approved backflow prevention assembly at each service connection to his premises. The consumer shall immediately install such approved assembly or assemblies at his own expense, and failure, refusal or inability on the part of the consumer to install such assembly or assemblies immediately shall constitute grounds for discontinuing water service to the premises until such assemblies have been installed and tested.

All passing test results shall be mailed to:

City of Girard Water Department  
100 W. Main St.  
Girard, OH. 44420

Or Emailed to:

[mscoville@cityofgirard.com](mailto:mscoville@cityofgirard.com).

## Section 2.

### **Definitions.**

- A. The following definitions shall apply in the interpretation and enforcement these rules and regulations:
1. “Air gap separation” means the unobstructed vertical distance through the free atmosphere between the lowest opening from any pipe or faucet supplying water to a tank, plumbing fixture, or other device and the flood level rim of the receptacle.
  2. “Approved” means that a backflow prevention device or method has been accepted by the City of Girard Water Department and the Safety Service Director as suitable for the proposed use.
  3. “Auxiliary water system” means any water system on or available to the premises other than the public water system and includes the water supplied by the system. These auxiliary waters may include water from another supplier’s public water system; or water from a source such as well, lakes, or streams; or process fluids; or used water; or water held in holding tanks. They may be polluted or contaminated or objectionable or constitute a water source or system over which the supplier or water does not have control.
  4. “Backflow” means the flow of water or other liquids, mixtures, or substances into the distributing pipes of a potable water supply from any other source other than the intended source of the potable water supply.
  5. “Backflow preventer” means an assembly, device, method, or type of construction intended to prevent backflow into a potable water system. Where backflow prevention device is used in other rules of this chapter (OAC 3745-95), this definition applies.
  6. “Certified Tester” any person who can test a backflow device that has been certified through The Department of Commerce (DOC) or the Operator Training Committee of Ohio (OTCO), and their certificate is current.
  7. “Consumer” means the owner or person in control of the premises supplied by or in any manner connected to a public water system.
  8. “Consumers water system” means any water system, located on the consumer’s premises, supplied by or in any manner connected to a public water system. A household plumbing system is considered to be a consumer’s water system.
  9. “Containment principle backflow preventer” means a backflow preventer that is installed in a consumer’s water system, that is intended to contain the water with in the premises to prevent any polluted or



contaminated water from backflowing into the public water system. Typically, the containment principle backflow preventer is placed at the service connection, unless placement is otherwise specified by rule herein.

10. “Contamination” means an impairment of the quality of the water by sewage or process fluid or waste to a degree which could create an actual hazard to the public health through poisoning or through spread of disease by exposure.
11. “Cross-connection” means any arrangement whereby backflow can occur.
12. “Degree of hazard” is a term derived from an evaluation of the potential risk to health and the adverse effect upon the potable water system
13. “Director” means the director of the Ohio Environmental Protection Agency or his duly authorized representative.
14. “Double check valve assembly” means an assembly composed of two single, independently acting, check valves including tightly closing shutoff valves located at each end of the assembly and suitable connections for testing the water-tightness of each check valve.
15. “Health hazard” means any condition, device, or practice in a water system or its operation that creates, or may create, a danger to health and well-being of users. The word “severe” as used to qualify “health hazard” means a hazard to the health of the user that could reasonably be expected to result in significant morbidity or death.
16. “Interchangeable connection” means an arrangement or device that will allow alternate but not simultaneous use of two sources of water.
17. “Non-potable water” means water not safe for drinking, personal, or culinary use.
18. “ODOC” means the Ohio Department of Commerce.
19. “OTCO” means Operators Training Committee of Ohio.
20. “Person” means the state, any political subdivision, public or private corporation, individual, partnership, or other legal entity.
21. “Pollution” means the presence in water of any foreign substance that tends to degrade its quality so as to constitute a hazard or impair the usefulness or quality of the water to a degree which does not create an actual hazard to the public health but which does adversely and unreasonably affect such water for domestic use.
22. “Potable water” means water which is satisfactory for drinking, culinary, and domestic purposes and meets the requirements of the Ohio Environmental Protection Agency.

23. "Premises" means any building, structure, dwelling or area containing plumbing or piping supplied from a public water system.
24. "Process fluids" means any fluid or solution which may be chemically, biologically or otherwise contaminated or polluted in a form or concentration such as would constitute a health, pollutional, or system hazard if introduced into the public or potable consumer's water system. This includes, but is not limited to:
  - a. Polluted or contaminated waters;
  - b. Process waters;
  - c. Used waters originated from public water system which may have been deteriorated in sanitary quality;
  - d. Cooling waters;
  - e. Contaminated natural waters taken from wells, lakes, streams, or irrigation systems;
  - f. Chemicals in solution or suspension; and
  - g. Oils, gases, acids, alkalis, and other liquid and gaseous fluids used in industrial or other processes, or for firefighting purposes.
25. "Public water system" has the meaning ascribed to such term in Section 6109.01 and 6109.02 of the Ohio Revised Code.
26. "Reduced pressure principle backflow prevention assembly" means an assembly containing a minimum of two independently acting check valves together with an automatically operated pressure differential relief valve located together with an automatically operated pressure differential relief valve located between two check valves. During normal flow and the cessation of normal flow, the pressure between these two checks shall be less than the supply pressure. In case of leakage of either check valve, the differential relief valve, by discharging to the atmosphere, shall operate to maintain the pressure between the check valves at less than the supply pressure. The unit must include tightly closed shutoff valves located at each end of the device, and each device shall be fitted with properly located test cocks.
27. "Service connection" means the terminal end of a service line from the public water system. If a meter is installed at the end of the service, then the service connection means downstream end of the meter.
28. "Supplier of water" means the owner or operator of a public water system.
29. "System hazard" means a condition posing an actual or potential threat of damage to the physical properties of the public water system or a potable consumer's water system.

30. "Pollution hazard" means a condition through which an aesthetically objectionable or degrading material not dangerous to health may enter the public water system or a potable consumer's water system.
31. "Used water" means any water supplied by a supplier of water from a public water system to a consumer's water system after it has passed through the service connection and is no longer under control of the supplier.

### **Section 3.**

#### **Installation of Devices.**

- A.** All Backflow Prevention Assemblies (BPA) installed shall meet ASSE standards and must be installed directly down stream of water meter with no direct connections before the backflow preventer.
- B.** It is required by the City of Girard that for all closed systems using a containment BPA under Ohio Administrative Code Chapter 4101:3-6-01 Section 607.3 Thermal expansion control. Where a storage water heater is supplied with cold water that passes through a check valve, pressure reducing valve or backflow preventer, a thermal expansion tank shall be connected to the water supply pipe at a point that is downstream of all check valves, pressure reducing valves and backflow preventers. Thermal expansion tanks shall be sized in accordance with the tank manufacturer's instructions and shall be sized such that the pressure in the water distribution system shall not exceed that required by section 604.8.
- C.** All containment BPA must be tested at the time they are installed in all facilities and every 12 months thereafter by an approved and certified backflow tester from the City of Girard. All test results must be submitted within three days to the City of Girard Water Department by either mail or email, no faxes will be accepted.

Mailing address:

City of Girard Water - Backflow Administrator  
100 W. Main St.  
Girard, OH. 44420

Email address:

[mscoville@cityofgirard.com](mailto:mscoville@cityofgirard.com)

- D.** No ASSE 1013 BPA shall be installed in a pit. According to the manufacturer installation requirements.
- E.** All BPA's must be installed in the horizontal position and allow for access for testing and repair. The device should be set at a minimum of 12" from the wall and a minimum of 12" to 30" maximum from the floor. See Figure A-1 for proper horizontal installation. Vertical installation should only be

used if horizontal installation is not feasible and upon approval of the City of Girard. The assembly must also be certified effective by the manufacturer if installed in the vertical position. See Figure A-2 for proper vertical installation.

- F.** All side mounted test ports shall be facing inside the room for testing purposes, if not able to have facing room side, they must be accessible for testing and repairing the BPA.
- G.** The installation of all BPA shall be sized according to the size of the meter installed.
- H.** If a facility is in need of a continuous water service, it is strongly recommended that a bypass with an appropriate BPA be installed to the bypass to allow continuous flow during BPA testing and repairs. Both BPA will need to be tested annually and all test results shall be submitted to the city of Girard Water Department within 3 days.
- I.** Any bypass that is needed by the facility, is required by the City of Girard to have the same type of BPA that is installed at the service connection for a total of two devices. Both BPA's shall be tested annually and all test results shall be submitted to the City of Girard Water Department within 3 days.
- J.** All BPA installations shall be approved by the City of Girard Water Department.
- K.** Every five years, a BPA survey shall be completed by the facility and returned to the City of Girard Water Department with 7 days of receiving the survey.

## Section 4.

### **Backflow Prevention Devices**

- A. There is a wide range of BPA's and devices available to protect the public water system. It is important to know the advantages and limitations of each device.

The selection of the appropriate assembly, device or ancillary equipment to use is based upon an elevation of the degree of hazard presented by the cross-connections found at the premises, which is then compared to the type of protection specified by the OEPA.

Each assembly has specific advantages, limitations and installation requirements.

1. **Approved Air-Gap Separation ANSI 112.1:** is used for a Severe Health Hazard, Health Hazard, System Hazard, Pollution Hazard, and protects the system from backpressure and back siphonage.

An air gap device must be used for filling all tanker trucks and any other water hauling vehicles which are considered a severe health hazard. No tanker truck shall be permitted to be filled with a direct connection to or submerged into the tank of the truck an air-gap must be established.

All temporary services seeking an air gap must be approved by the City of Girard backflow personnel.

2. **Reduced Pressure Assembly ASSE 1013:** is used for Health Hazard, System Hazard, Pollution Hazard, and protects the system from backpressure and back siphonage.
3. **Reduced Pressure Detector Assembly ASSE 1047:** is used for Health Hazard, System Hazard, Pollution Hazard, and protects the system from backpressure and back siphonage. This is used for a dedicated Fireline.
4. **Double Check Valve Assembly ASSE 1015:** is used for Pollution Hazard and protects the system from backpressure and back siphonage.
5. **Double Check Detector Assembly ASSE 1048:** is used for Pollution Hazard and protects the system from backpressure and back siphonage. This is used for a dedicated Fireline.

6. **Pressure Vacuum Breaker ASSE 1020:** is used for Health Hazard, System Hazard, Pollution Hazard, and protects the system from back siphonage. This device is used for irrigation.

**B.** Additional considerations are piping size where the backflow prevention devices must be at least the same size as the meter installed; location and the need to test the devices annually.

## **Section 5.**

### **Water System**

- A.** The water system shall be considered as made up of two parts: the public water system and the consumer's water system.
- B.** The public water system shall consist of the source facilities and the distribution system, and shall include all those facilities of the water system under the control of the Safety Service Director or any of his authorized representatives up to the point where the consumer's water system begins.
- C.** The source shall include all components of the facilities utilized in the production, treatment, storage and delivery of water to the public distribution system.
- D.** The public distribution system shall include the network of conduits used for delivery of water from the source to the consumer's water system.
- E.** The consumer's water system shall include those parts of the facilities beyond the service connection which are utilized in conveying water from the public distribution system to the point of use.



## Section 6.

### **Cross-Connections Prohibited**

- A.** No water service connection shall be installed or maintained to any premises where actual or potential cross-connections to the public potable or consumer's water system may exist unless such an actual or potential cross-connections are abated or controlled to the satisfaction of the Safety Service Director of the City of Girard or any of his authorized representatives.
- B.** No connection shall be installed or maintained whereby water from an auxiliary water system may enter a public water system and the method of connection and use of such system shall have been approved by the Safety Service Director of the City of Girard or any of his authorized representatives and the Director of the Ohio Environmental Protection Agency as required by **Section 6109.13** of the Ohio Revised Code.
- C. ORC Section 6109.13 Approval of connections to public water system.**

No official, officer, or employee in charge of or being employed in the maintenance and operation of a public water system and no other person, firm, or corporation shall establish or permit to be established any connection whereby water from a private, auxiliary, or emergency water system may enter the public water system, unless such private, auxiliary, or emergency water system, and the method of connection and use of such system, has been approved by the environmental protection agency.

## **Section 7.**

### **Survey and Investigations**

- A.** The consumer's premises shall be open at all reasonable times to the Safety Service Director, or his authorized representative, for the conduction of surveys and investigations of water use practices within the consumer's premises to determine whether there are actual or potential cross-connections to the consumer's water system through which contaminants or pollutants could backflow into the public potable water system.
  
- B.** On request by the Safety Service Director, or his authorized representatives, the consumer shall furnish information on water use practices within his premises.
  
- C.** It shall be the responsibility of the water consumer to conduct periodic surveys of water use practices on his premises to determine whether there are actual or potential cross-connections in his system through which contaminants or pollutants could backflow into his or the public water system, surveys shall be completed every 5 years. The first survey shall be done by the city with a full inspection of the facility. Random inspections shall be conducted thereafter.

## Section 8.

### **Where Protection is Required**

- A.** An approved BPD shall be installed on each service line to a consumer's water system serving premises, where in judgment of the Safety Service Director, or an authorized representative, actual or potential hazards to the public potable water system exist.
  
- B.** An approved BPD shall be installed on each service line to a consumer's water system serving premises where the following conditions exist:  
Premises having an auxiliary water system, unless such auxiliary water system accepted as an additional source by the Safety Service Director of the City of Girard, an authorized representative of his and the Director of the Ohio Environmental Protection Agency;
  - 1.** Premises on which any substance is handled in such a fashion as to create an actual or potential hazard to the public potable water system.  
This shall include premises having sources or system which are no longer under the sanitary control of the Safety Service Director;
  - 2.** Premises having internal cross-connections that, in the judgment of the Safety Service Director, or his authorized representative, are not correctable, or intricate plumbing arrangements which make it impractical to determine whether or not cross-connections exist;
  - 3.** Premises, where, because of security requirements or other prohibitions or restrictions, it is impossible or impractical to make complete cross-connection survey;
  - 4.** Premises having a repeated history of cross-connections being established or re-established;
  - 5.** Others specified by the Safety Service Director of the City of Girard, or his authorized representative
  
- C.** An approved BPA shall be installed on each service line to a consumer's water system serving, but not limited to, the following types of facilities unless the Safety Service Director, or an authorized representative, determines that no actual or potential hazard to the public water system exists;

1. Hospitals, mortuaries, medical clinics, doctor's offices, dentist offices, veterinary clinics, and nursing homes;
2. Laboratories;
3. Piers, docks, waterfront facilities;
4. Sewage treatment plants, sewage pumping stations or storm water pumping stations;
5. Food or beverage processing plants;
6. Restaurant's;
7. Any premises serving carbonated beverages;
8. Chemical plants;
9. Metal plating industries;
10. Petroleum processing or storage plants;
11. Radioactive material processing plants or nuclear reactors;
12. Car/truck washes;
13. Any others specified by the Safety Service Director of the City of Girard, or by one of his authorized representatives.

**D.** An approved BPA shall be installed at any point of connection between the public or consumer's water system and an auxiliary water system unless such auxiliary system is accepted as an additional source by the Safety Service Director, or one of his authorized representatives, and the Director of the Ohio Environmental Protection Agency.

## Section 9.

### **General**

- A.** Under Ordinance 6191-90, the Safety Service Director of the City of Girard, or one of his authorized representatives has the right to request that a backflow prevention device be installed at any City of Girard water service connection to prevent the contamination to the City's public water system.
- B.** The City of Girard water department has the right to enter any premises for inspection of the consumer's water system to ensure that the proper backflow protection device is correctly installed, tested, and to assess the premises for potential hazards to the public water system. Under Ordinance 6191-90 Section (5).
- C.** Ordinance 6191-90 Section (5) states the Director of Public Service, or his duly authorized representative, shall have the right to enter, at any reasonable time, at any property served by a connection to the public water supply or distribution system of the City of Girard for the purpose of inspecting the piping system or systems thereof. On property so served shall furnish to the said Director any information that he may request regarding the piping system or systems of water use on such property. The refusal of such information, when demanded, shall, within the discretion of said Director be deemed evidence of the presence of improper connection as provided in this Section and Chapter.
- D.** The City of Girard Director of Public Service, has the right to shut off water to any said premises if these rules and regulations are not followed, if the information is not given, or the proper devices are not installed within a said given time to correct any problems found during an inspection or upon discovering the improper device is installed. Under Ordinance 6191-90 Section 6.
- E.** Ordinance 6191-90 Section 6 states the Director of Water Utility Operations is hereby authorized and directed to discontinue, after reasonable notice to the occupant thereof the water service to any property wherein any connection in violation of the provisions of this Section or Chapter is known to exist, and to take such other precautionary contamination of the public

water supply distribution mains. Water service to such property shall not be restored until such conditions shall have been eliminated or corrected in compliance with the provisions of this Section, Chapter and any other applicable laws and regulations.

- F.** A certified tester from the City of Girard has the right to randomly test any containment devices that protect the City of Girard public water system, given reasonable notice and a scheduled test shall be performed as to not interfere with the normal working conditions of the said premises. If only time to perform said test may cause a disruption of service, the disruption shall be as reasonable as possible.

*See APPENDIX G for the full City of Girard Ordinance 6191-90*

## **Section 10.**

### **Types of Protection Required**

- A.** The type of protection required under Sections 8.A, 8.B, and 8.C of these regulations shall depend on the degree of hazard which exists as follows:
1. An approved air gap separation ANSI 112.1 shall be installed where the public water system may be contaminated with substances that could cause severe health hazard;
  2. An approved air gap separation ANSI 112.1 or an approved reduced pressure principle backflow prevention assembly ASSE 1013 shall be installed where the public water system may be contaminated with any substance that could cause a system or health hazard;
  3. An approved air gap separation ANSI 112.1 or an approved reduced pressure principle backflow prevention assembly ASSE 1013 or an approved double check valve assembly ASSE 1015 shall be installed where the public water system may be contaminated with any substance that could cause a pollution hazard not dangerous to health;
- B.** The type of protection required under Section 8.D of these regulations shall be an approved air gap separation ASNI 112.1 or any interchangeable connection.
- C.** Where an auxiliary water system is used as a secondary source of water for a fire protection system, the provisions of Section 10.B for an approved air gap separation or an approved interchangeable connection may not be required, provided:
1. At premises where the auxiliary water system, may be contaminated with substances that could cause a system or health hazard, the public consumer's potable water system shall be protected against backflow by installation of an approved reduced pressure principle BPA ASSE 1013;
  2. At all other premises, the public or consumer's potable water system shall be protected against backflow by the installation of either an approved reduced pressure principle BPA ASSE 1013 or an approved double check valve assembly ASSE 1015;

3. The public or consumer's potable water system shall be the primary source of water for the fire protection system;
4. The fire protection system shall be normally filled with water from the public or consumer's potable water system;
5. The water in the fire protection system shall be used for fire protection only, with no regular use of water from the fire protection system downstream from the approved BPA;
6. The water in the fire protection system shall contain no additives.



## Section 11.

### **Backflow Preventers**

- A.** Any BPA required by these rules and regulations shall be of a model or construction approved by the Safety Service Director of the City of Girard, or one of his authorized representatives and the Director and shall comply with the following:
1. An air gap separation, to be approved, shall be at least twice the diameter of the supply pipe, measured vertically above the top of the rim of the vessel, but in no case less than one inch. I shall meet the requirements of OAC Rule 3745-95-04 Of the Ohio Environmental Protection Agency. OCA 3745-95-04 can be found in the Appendices.
  2. A double check valve assembly ASSE 1015 or a reduced pressure principle BPA ASSE 1013, shall be approved by the Safety Service Director of the City of Girard, or one of his authorized representatives, and shall meet the requirements of OAC Rule 3735-95-04 of the Ohio Environmental Protection Agency.
  3. An interchangeable connection, to be approved, shall be either a swing type connector or a four-way valve mechanism which unseats the plug, turns it ninety degrees and reseats the plug. Four-way valves shall stop valves on each pipe connected the valve. The telltale port on the four-way shall have no piping connected and threads or flange on this port shall be destroyed so the connection cannot be made.
- B.** Existing backflow preventer approved by Safety Service Director of the City of Girard, or one of his authorized representatives and the Director at the time of the installation and properly maintained shall, except for inspection, testing and maintenance requirements, be excluded from the requirement of Section 11.A of this regulation providing the Safety Service Director of the City of Girard, or one of his authorized representatives and the Director are assured that they will satisfactorily protect the public potable water system. Whenever the existing BPA is moved from the present location or requires more than minimum maintenance or when the Safety Service Director of the City of Girard, or one of his authorized representatives finds that the maintenance of the BPA constitutes a hazard to health, the BPA shall be replaced by a BPA meeting the requirements of these regulations.

## Section 12.

### **Approved Certified Testers**

- A.** Anyone desiring to be accepted as an approved Certified Backflow Assembly Tester in the City of Girard must submit to the backflow administrator the following:
1. A current copy of their current state certification showing their expiration date. Upon renewal of certification, a copy of the renewed certification shall be sent to the backflow administrator with 7 days of receipt of certification, in order to be recognized by the City of Girard.
  2. A current copy of backflow testing device calibration must be submitted to the City of Girard backflow administrator along with state certification. The device must be calibrated and certified annually and the results submitted with 7 days of receipt of calibration results.
  3. The City of Girard is requiring all testers to tag all containment and fire backflow prevention assemblies with the tags that are sent to the premises of the consumers of potable water for each device. All tag information must be filled in, a signature or initials, testing date and test results of pass or fail, the tags are good for several years and will only need replaced when tag is full. When a tag is filled up, it shall be sent by mail to the City of Girard backflow administrator. If your company already does this, your company tags will be accepted.
  4. Only the approved test sheets that are sent to the consumer of potable water's premises shall be accepted. Only test results that are legible will be accepted. All test sheets shall either be submitted to the City of Girard backflow administrator by either e-mail or mailed within 3 days of testing, no faxes will be accepted.
  5. All Ohio State DOC certified backflow prevention assembly testers and OTCO certified backflow prevention assembly testers are able to test in the City of Girard for containment, as long as the requirements for Section 12. A.1. are met.
  6. All test results that are being submitted through e-mail may send them to the following:

E-mail address:

[mscoville@cityofgirard.com](mailto:mscoville@cityofgirard.com)

7. All test results that are mailed in should be mailed to:

City of Girard Water - Backflow Administrator  
100 W. Main St.  
Girard, OH. 44420

8. Any failing test results must be reported to the City of Girard backflow administrator immediately. The device must either be repaired or replaced within 3 days and a good test result must be submitted to the City.
9. Any failure to notify all failed BPA's test results to the City of Girard backflow administrator may result in the removal of the certified tester from the City of Girard's approved certified testers list upon discovering that it was not reported by the backflow administrator.
10. The City of Girard's backflow administrator must be OTCO certified tester and has the right to test any containment device within the City of Girard's water distribution system. Tests will be done on containment devices periodically throughout the year and devices will be randomly selected.
11. If a discrepancy is noticed with a test result received, the City may retest a containment device, to make sure that there are no problems with that certain BPA, at no cost to the consumer. The tester will be notified and if they would like to be present during the testing, arrangements will be made for them to be there.
12. If there is a discrepancy with a fire device, the City may request with their presence, a second test be run on the device, with no charge to the consumer.
13. A complete list of currently approved BFP testers will be posted on the City of Girard website under Water. [www.cityofgirard.com](http://www.cityofgirard.com) and **APPENDIX I.**

### **Section 13.**

#### **Backflow Prevention Assembly Maintenance and Testing**

- A.** It shall be the duty of the consumer at any premises on which a BPA is required by these regulations are installed to have inspections, testing and maintenance made in accordance with the following schedule, or more often where inspections indicate a need:
1. Air gap separations shall be inspected at the time of installation and at least every twelve months thereafter;
  2. Double check valve assemblies shall be inspected and tested for tightness at the time of installation and at least every twelve months thereafter;
  3. Reduced pressure principle backflow prevention assemblies shall be inspected and tested for tightness at the time of installation and at least every twelve months thereafter;
  4. Interchangeable connections shall be inspected at the time of installation and at least every twelve months thereafter;
- B.** Inspections, tests, and maintenance of BPA's shall be made at the expense of the water consumer and shall be performed by any person deemed a Certified tester according to the said definition "Certified Tester". OTCO certified backflow testers are only permitted to test and repair containment assemblies only. ODOC certified testers can test and repair containment and isolation devices.
- C.** Whenever BPA's required by these regulations are found to be defective, they shall be repaired, overhauled or replaced at the expense of the consumer without delay.
- D.** The water consumer must maintain a complete record of each backflow preventer from purchase to retirement. This shall include a comprehensive listing that includes a record of all tests, inspections, repairs, and overhauls. Records of inspections, tests, repairs, and overhauls shall be submitted to the City of Girard backflow administrator.

- E. Backflow preventers shall not be bypassed, made inoperative, removed or otherwise made ineffective without specific authorization by the City of Girard backflow administrator.

#### **Section 14.**

### **Booster Pumps**

- A. For booster pumps not intended to be used for fire suppression, such booster pump shall be equipped with a low-pressure cut-off designed to shut-off the booster pump when the pressure in the service line in the suction side of the pump drops below 10 psi or less.
- B. For booster pumps, or fire pumps, used for fire suppression installed after August 8, 2008, such booster pump, or fire pump, shall be equipped with one of the following:
  - 1. A low suction throttling valve on the booster pump discharge, which throttles the discharge of the pump when necessary so that suction pressure will not be reduced below 10 psi while the pump is operating; or,
  - 2. The fire pump is equipped with a variable speed suction limiting control on the booster, or fire, pump. The speed control system must be used to maintain a minimum suction pressure of 10 psi at the pump inlet by reducing the pump driver speed while monitoring pressure in the suction piping through a sensing line.
- C. It shall be the duty of the water consumer to maintain the low pressure cut-off device, low suction throttling valve, or variable speed suction limiting control, in proper working order and to certify to the City of Girard backflow administrator, at least every twelve months that the minimum pressure sustaining method in place is operating properly.

## Section 15.

### **Fire Protection**

- A.** All fire protection must have its own separate water supply from the domestic line. The protection against backflow required on fire protection systems which do not include the use of auxiliary water supplies will depend on the details of the specific installation. Each installation must be evaluated individually on the basis of the degree of hazard it presents to the public water system. While the following does not cover all situations, it summarizes some typical requirements:
1. The installation of an approved BPA is usually not required for simple fire protection systems which contain no additives, are not equipped with booster pumps or jockey pumps, and cannot be connected to an auxiliary water supply. These are usually provided with either a simple sanitary check valve or a detector check valve.
  2. The City of Girard requires a double check valve assembly to prevent taste and odor problems from “breathing” of these fire systems due to water main pressure fluctuations.
  3. An approved double check valve assembly is required on the public water supply line for a fire system containing a jockey pump which could cause back pressure into the public water system and equipped with a booster.
  4. An approved reduced pressure principle BPA is required on the public water supply line serving a fire system containing any additive (even propylene glycol) or which can be connected to an auxiliary water supply.
- B.** In determining a degree of hazard, the local fire department should be consulted to determine their practices in regards to their use of additives and whether they connect water from an auxiliary supply through their pumpers into Siamese connections.

- C.** In addition, if a BPA is installed within a fire protection system, the individual qualified to test the unit may also need a certification from the state fire marshal to test the BPA.
- D.** New installations on fire must have a testable protection device, for simple fire protection ASSE 1048 along with a water meter, as well as a double check detector ASSE 1015 as containment, downstream the water meter.
- E.** For fire protection with an additive added will be considered a health hazard ASSE 1047 reduced pressure assembly with a meter installed along with the device as well as an ASSE 1013 installed, downstream the water meter.
- F.** For a severe health hazard fire system shall require an air gap ANSI 112.1 downstream the meter, before the fire system.
- G.** All booster pumps shall be installed after the water meter and BPA.
- H.** For more information on fire protection please see Ohio Environmental Protection Agency's Division of Drinking and Ground Waters Backflow Prevention and Cross-Connection Control Fourth Edition-2015 handbook which is located at:  
[https://epa.ohio.gov/Portals/28/documents/rules/proposed/BFP-Manual\\_Final\\_Sept2015.pdf](https://epa.ohio.gov/Portals/28/documents/rules/proposed/BFP-Manual_Final_Sept2015.pdf).

## Section 16.

### **Other Hazards**

**A. Water Operated Sump Pumps/Devices:** Some devices use the pressure provided by the public water system to operate. For example, water-operated backup sump pumps for homes and businesses utilize water pressure through the venturi principle instead of electricity to power the movement of collected sump water to the building's drains. Such a configuration creates a cross-connection between the potable public water supply and liquid of a questionable quality. Due consideration must be given to the level of protection that is necessary to mitigate the hazard associated with the cross-connection. If alternative means exist which do not utilize water pressure or public water supply to operate the unit, they should take priority.

Specifically, for water-operated backup sump pumps the following shall be taken into consideration:

1. Water-operated sump pose a potential backflow hazard by way of a cross-connection between the drinking water supply and contaminated water in the sump pit. The hazard is increased during flooding conditions. The main sump pump offers a potential of imposing backpressure against the water supply line to the water-operated back up sump pump if the discharge lines are combined. A majority of these pumps provide a vacuum breaker device for protection against back siphonage. A vacuum breaker device would not provide the level of protection necessary if a backpressure situation should occur and would be made obsolete if it became submerged during a flooding situation.
2. The public water system purveyor must analyze each household or building considering installation of a water-operated sump pump on an individual basis to determine if a backflow hazard has been mitigated.
3. In all situations in which a water-operated backup sump pump is installed, the main sump pump and the water-operated backup sump pump should have completely separate discharge piping. Separate



- discharge piping is necessary if the backflow preventer installed is not rated for backpressure.
4. The installation of water-operated backup sump pump units should also be coordinated with the local building department, local health department, or the Ohio Department of Commerce, Industrial Compliance Division which regulates larger residential and commercial plumbing applications. For installation in a non-residential building, one of these authorities will approve the plans and inspect the plumbing installation to ensure that proper backflow prevention is provided. For residential buildings, the proposed plumbing installation may be reviewed and inspected where a local certified building department or a local health department is available to enforce the plumbing code. At time of issuance, the relevant sections of the OPC include sections 608.3, 608.12, 608.16.6, and 1113.1.5 (Rules 4101:3-6-01 and 4101:3-11-01 of the Administrative Code).
  5. An ASSE 1013 backflow device must be installed on the premises if a water-operated sump pump is installed, if no backflow device is installed, the water-operated sump pump must be removed from the premises.

**Figure 44.** Provides a schematic of a water-operated backup sump pump.

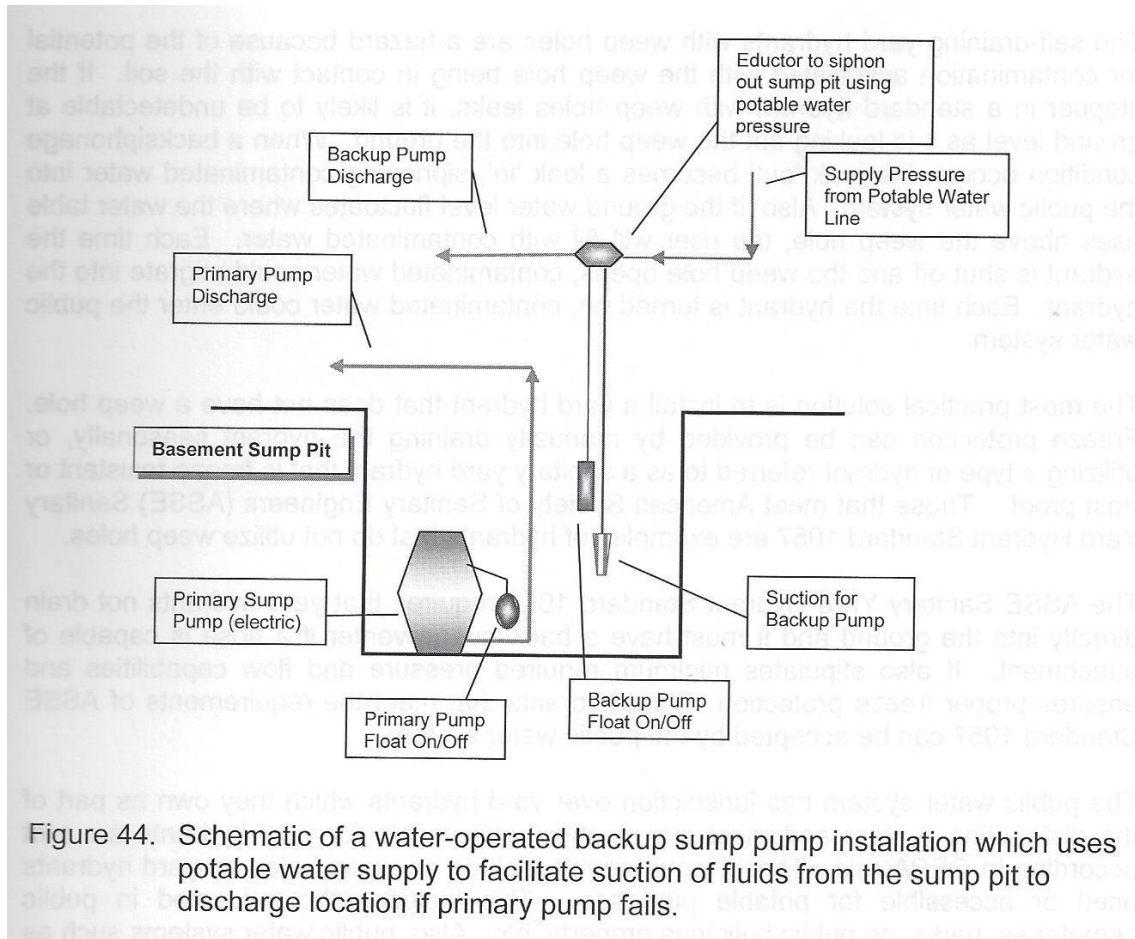

Figure 44. Schematic of a water-operated backup sump pump installation which uses potable water supply to facilitate suction of fluids from the sump pit to discharge location if primary pump fails.

**Figure 44.**

**B. Yard Hydrants:** Yard hydrants are commonly used in areas where water is needed from a building. **Figure 45 A.** illustrates an installation of a yard hydrant. The standard yard hydrant consists of a head for attaching a hose, a riser pipe and a shutoff valve below the frost level. Yard hydrants are often equipped with weep holes below ground. When the hydrant is shut off, the weep holes in the valve open, allowing the water from the riser to drain into the soil below the frost line. The self-draining yard hydrant inherently provides protection against freezing. Weep holes are illustrated in **Figure 45 B.**

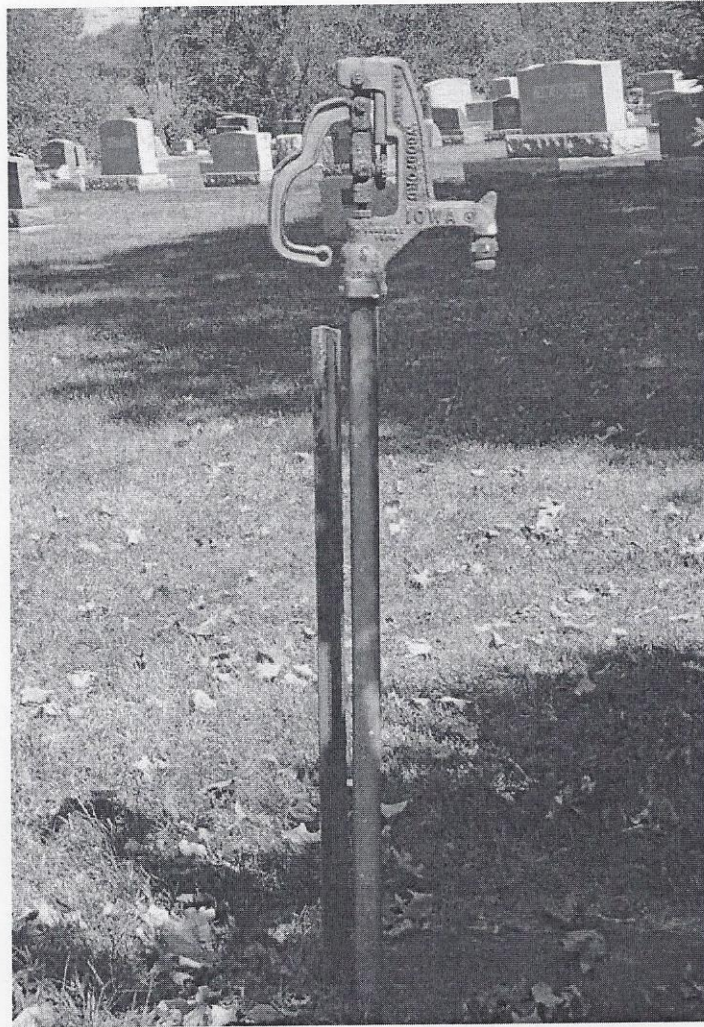

Figure 45A. An installation of a self-draining, non-sanitary type yard hydrant.

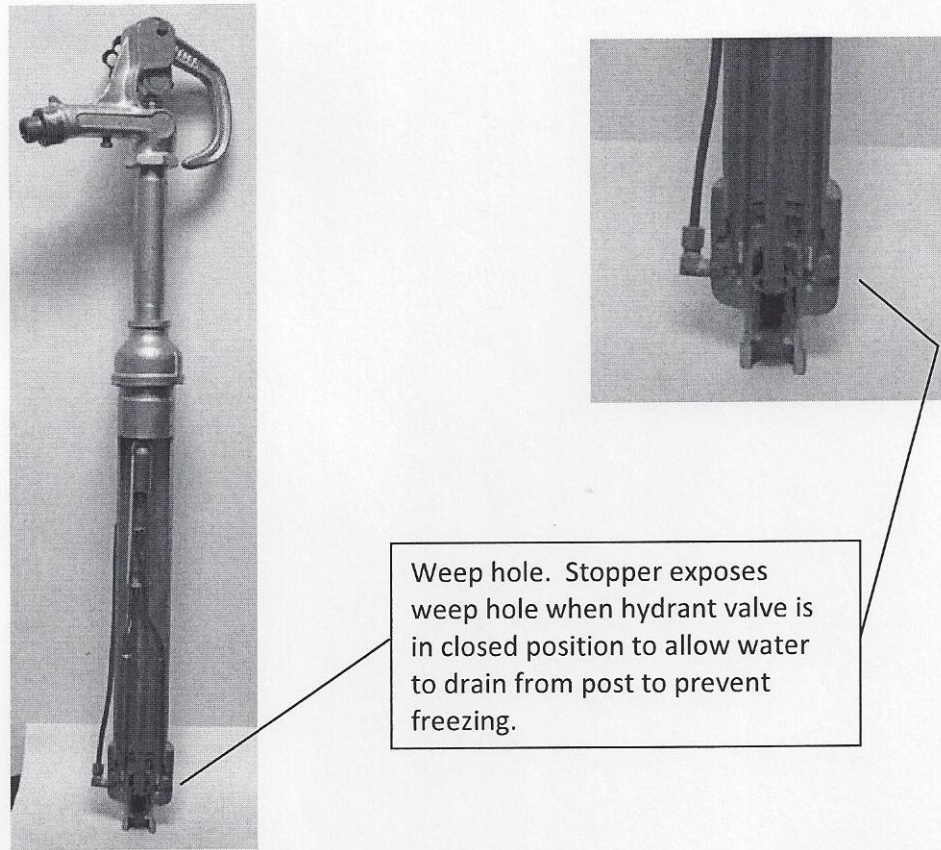

Figure 45B. Cross-section of non-sanitary type yard hydrant with weep hole.

Yard hydrants, in general, create a potential for back siphonage every time that are shut off, as the draining riser creates siphon at the hose bib. Protection should be provided by installing a hose bib vacuum breaker in all yard hydrants where a hose can be attached.

The self-draining yard hydrants with weep holes are a hazard because of the potential for contamination associated with the weep hole being in contact with the soil. If the stopper in a standard hydrant with weep holes leaks, it is likely to be undetectable at ground level as it is leaking out the weep hole into the ground. When back siphonage condition occurs, the leak 'out' becomes a leak 'in', siphoning contaminated water into the public water system. Also, if the ground water level fluctuates where the water table rises above the weep hole, the riser will fill with contaminated water. Each time the hydrant is shut off and the weep hole opens, contaminated water could

migrate into the hydrant. Each time the hydrant is turned on, contaminated water could enter the public water system.

The most practical solution is to install a yard hydrant that does not have a weep hole. Freeze protection can be provided by manually draining the hydrant seasonally, or utilizing a type of hydrant referred to as a sanitary yard hydrant that is freeze resistant or frost proof. Those that meet American Society of Sanitary Engineers (ASSE) Sanitary Yard Hydrant Standard 1057 are examples of hydrants that do not utilize weep holes.

The ASSE Sanitary Yard Hydrant Standard 1057 requires that yard hydrants not drain directly into the ground and it must have a backflow preventer if a hose is capable of attachment. It also stipulates minimum required pressure and flow capabilities and ensures proper freeze protection. Yard hydrants that meet the requirements of ASSE Standard 1057 can be accepted by the public water system.

The public water system has jurisdiction over yard hydrants which they own as part of the distribution system and must ensure the requirements for yard hydrants are met according to OEPA rule. These requirements include no weep holes on yard hydrants used or accessible for potable water purposes. This includes those located in public cemeteries, parks, on public buildings property, etc. Also, public water systems such as campgrounds, schools or mobile home parks, have the responsibility to ensure the requirements for yard hydrants are met. Yard hydrant requirements are full outlined in Ohio Administrative Code Rule 3745-95-09. (See LAW Writer Ohio Laws and Rules website at <http://codes.ohio.gov/> to view this rule and other regulations in Ohio.)

Yard hydrants located on private property served by a public water system must be considered when determining the degree of hazard and the necessary backflow prevention required at the meter. Yard hydrants with weep holes present a hazard as well as those with unprotected hose bibb connections.

Self-draining yard hydrants shall be labelled non-potable and shall have an appropriate BFA installed at the service connection.

**C. Geothermal Heating and Cooling Systems:** If a geothermal heating and/or cooling system is installed at a premise served by the public water system, the system must be considered when identifying and hazards to the public water system. Two different scenarios have been identified:

1. In a closed loop system, a heat transfer fluid is recirculated through a loop of piping installed below ground or within a surface water body. No withdrawal of groundwater is involved. An antifreeze additive may be used to facilitate to heat exchange which may be toxic. The components of the geothermal heating and/or cooling system must be kept completely separate, physically, from any plumbing or fixtures supplied by the public water system. If the potential exists such that the heat transfer fluid from the geothermal system can be introduced into the plumbing supplied by the public water system, a reduced pressure principle BPA must be installed at the service connection.
2. If a geothermal system is an open loop system, such that water for circulation is pumped from a well and discharged to another well or surface water, consideration must be given to whether or not the non-potable supply can be introduced into the potable water supply provided by the public water system. The potable and non-potable supply piping must be completely separated, physically, and appropriate backflow preventer installed at the service connection. If the potential exists such that fluid from the geothermal system (including the water source, circulating fluid, or discharge) can be introduced into the plumbing supplied by the public water system, a reduced pressure principle BPA must be installed at the service connection.

For a public water system that uses an approved well for the both a source of drinking water and a source for the heat exchange fluid in an open-looped geothermal system, a reduced pressure principle BPA must be used in direct contact with the water. Discharge to surface water must also be through an air gap.

**D. Gray Water Systems and Rain Water Harvesting Systems:** Grey water systems can be defined as a system that treats and reuses wastewater discharged from lavatories, bathtubs, showers, clothes washers, and laundry sinks that does not contain food wastes or bodily wastes. A gray water piping system usually contains a collection basin and pumps or gravity

design and piping to carry collected used water to non-potable fixtures such as for flushing toilets or irrigation.

A rainwater harvesting system can be defined as storm water that is conveyed from a building roof, stored in a cistern and disinfected and filtered before use. Typically, when public water supply is available, the collected rainwater has been used for toilet flushing or landscape irrigation. These systems can be equipped with tanks and pumps to move the collected water.

Both of these systems represent an auxiliary water supply and pose a hazard for backflow into the public water system supply and into the consumer's water supply.

The potable system supplied by the public water system must be kept physically separated from the gray water system or the rain water installed at the service connection. The potable supply may supplement the non-potable supply through the use of an air gap and tank configuration. In addition, the Ohio plumbing code would prohibit any physical connection between a make-up water line from the potable water system and the gray water system (see code reference in Appendix I). All plumbing and fixtures available for use for human consumption purposes must be supplied with potable water. The non-potable piping should be labeled or color-coded, and a food grade dye should be used in the non-potable supply as an indicator of the source of supply and to differentiate it from the potable water supply.

**E. Temporary Services:** All temporary services include hydrants or whichever method of temporary service must have a BPA installed before water meter. The BPA must be tested every time it is removed and reinstalled by a certified BPA tester and all test results must be sent to the City of Girard water.

1. All temporary services must have a reduced pressure principle ASSE 1013 BPA installed before the meter and tested by a certified backflow tester. All test results must be sent to the City of Girard,
2. All temporary methods used for construction purposes shall be installed with a reduced pressure principle ASSE 1013 BPA.
3. If filling tanker trucks, an approved air-gap ANSI 112.1 must be established before filling or using any public water source. No tanker truck shall be permitted to be filled with a direct connection to the public water system or with a hose submerged into the tank of the tanker.

4. Before any temporary services for applying an air gap, it must be approved by the City of Girard backflow administrator and will be monitored to ensure that this practice is used. If failure to comply with these rules and regulations, the water supply will be discontinued and an alternative source will have to be made, at the water consumer's own expense.

**F. Reduced Pressure Principle / Air Gap Relief Port Discharge:** Under plumbing code 608.14.2.1 Relief Port piping, the relief port piping-the termination of the piping from the relief port of a reduced pressure principle BPA or air gap fitting shall be discharged to an approved indirect waste water receptor or to the outdoors where it will not cause any harm or damage, or create a nuisance to the consumer's premises.

**G. Wells:** All private wells shall be sealed according to OAC 3745-9-10 when there is a connection made to the City of Girard public water system.

1. Whenever a consumer wishes to switch from well water on their property to connect to the City of Girard water system, the well must be abandoned and sealed according to OAC 3745-9-10.
2. There will be no exceptions to this rule.



## Section 17. Evaluating Degree of Hazard

- A. Before you can determine the type of BPA to require at the premises, you must first evaluate the degree of hazard that the premises present to the public water system.
- B. At an existing building, this evaluation is accomplished by an on-site survey of the piping and equipment that is connected to the water user's system. The Ohio EPA backflow prevention regulations are retroactive; therefore there is no "*Grandfather Clause*" even though the service connection may have existed prior to the regulations.
- C. In the instance of a proposed building, a preliminary evaluation should be made during the planning stage by reviewing the engineer's mechanical, plumbing, waste and fire protection plans for probable cross-connections. The premises should then be inspected after completion of the building to validate that no changes or additions have been made to the piping.
- D. Your evaluation of degree of hazard should first take into account the "*potential for backflow to occur*" and the "*toxicity of the substances that could backflow*".
- E. The potential for backflow to occur due to an actual or potential cross-connection is the first determination that must be made. An unprotected cross-connection is of course an absolute hazard, but the potential must also be considered that internal protective devices may be removed or bypassed, equipment may be used incorrectly, or an inadvertent action on the part of the water user may result in a backflow condition.

### **Potential cross-connection exist if:**

1. A premise has an auxiliary water system available to it.
2. There are existing interchangeable connections.
3. Internal cross-connections are not correctable or are too intricate to be easily traced.
4. Any substance is handled in such a fashion as to create a hazard to the public system.
5. Security restrictions prohibit a complete internal survey.
6. The premises have a repeated history of cross-connections being established or re-established.

- F. You then need to evaluate the toxicity of the substances that could backflow to determine if they present a danger to the health of the water users or will cause physical damage to the public water system, or are simply aesthetically objectionable.
- G. When evaluating the degree of hazard, you must be attentive to the substances that may enter the water system. You should be familiar with the toxicity of those substances, be able to identify the actual cross-connections whereby those substances can enter the public water system, and finally visualize the potential cross-connections that can be created.
- H. Evaluating the degree of hazard is not an exact science and although guidelines have been developed to assist you in your evaluation, the final decision rests with you the supplier of water.  
**“The best protection against backflow is the elimination of all cross-connections”**
- I. However, this is not always possible due to the mechanical design and function of some equipment. Additionally, in many buildings such as factories, power plants, and hospitals, the potable water, waste, heating, and cooling piping is concealed within the structure of the building.
- J. Under these circumstances, identification and removal of all cross-connections, either actual or potential, within the water user’s system may be impossible and an approved BPA should be installed at the service connection. This type of protection is called the containment principle of backflow prevention and is a responsibility of the supplier of water.
- K. However, the containment principle of backflow prevention protects only the public water system and does not protect the water user for himself.
- L. The responsibility and authority for protecting the water user’s system rests with the local plumbing officials. It is their purview to require specific protection at the individual fixture which is called the isolation principle of backflow prevention. The water user’s system is protected by the installation of an isolation device at the individual fixture.
- M. Remember the supplier of the water has the authority to require a containment principle BPA at any premises regardless of the internal protection afforded at the individual fixtures.

## **Ohio EPA Degree of Hazard**

The Ohio EPA specifies that there are four degrees of hazard.

### **A. Pollution Hazard**

Is a pollutant that degrades the water quality; may affect color, taste or odor; is aesthetically objectionable, but poses no threat to health or piping.

### **B. System Hazard**

Is a condition, device, or practice posing an actual or potential threat of damage to the physical properties of the public water system or a consumer's water system. Pipes, pumps, or regulators.

### **C. Health Hazard**

Is a condition, device, or practice in a water supply system or its operation that creates, or may create, a danger to the health and well being of users. Restaurants.

### **D. Severe Hazard**

Is a threat to the health of a user that could reasonably be expected to result in death or significant morbidity.

### **E. The Containment protection required shall depend on the degree of the hazard as follows.**

1. An approved air gap separation shall be installed where the public water system may be contaminated with substances that could cause a severe health hazard.
2. An approved air gap separation or an approved reduced pressure assembly shall be installed where the public water system may be contaminated with substances that could cause a system or health hazard.
3. An approved air gap separation or an approved double check assembly shall be installed where public water system may be contaminated with any substance that could cause a pollution hazard.

### **Degree of Hazard**

### **Minimum Protection Required**

Severe Health Hazard

Approved Air-Gap Separation

Health Hazard

Reduced Pressure Assembly

System Hazard

Reduced Pressure Assembly

Pollution Hazard

Double Check Valve Assembly

**F. Comparison of Degree of Hazard**

1. The type of backflow prevention device that will be required at the water meter is determined by an evaluation of the degree of hazard that is presented.
2. When we speak of evaluating the degree of hazard, we are going to determine the potential for backflow to occur (can backflow happen) and the toxicity of the containment that could backflow (how toxic is the substance that can backflow into the piping).
3. The Water supplier under the direction of the Ohio Environmental Protection Agency determines the total degree of hazard presented by the premises and determines the appropriate containment BPA that must be installed at the water meter.
4. The Plumbing Inspection Authority under the direction of the Ohio Department of Commerce determines the degree of hazard presented by the individual fixtures within the premises. Based upon this evaluation, they determine the appropriate isolation backflow prevention device that must be installed at the fixture.
5. Although the Ohio Department of Commerce and Ohio Environmental Protection Agency have different verbiage for the various degrees of hazard, there is a correlation between the two agencies as infected in the following chart.

**Degree of Hazard Evaluation Terms**

<b>Ohio Department of Commerce</b>	<b>Ohio Environmental Protection Agency</b>
Low Hazard	Pollution Hazard
High Hazard	System Hazard
High Hazard	Health Hazard
Severe High Hazard	Severe Health Hazard

For Severe Hazards: With a recommendation for an approved air-gap separation, this applies to:

1. Ethylene glycol systems
2. Sewage lift pumps

## **G. Typical Hazards**

The following is the typical degree of hazard and generic listing of equipment that you might expect to find at a specific facility. The list contains the usual equipment found at a particular facility but there may be others that are not listed here.

The list is not all-inclusive but gives you the minimum degree of hazard normally found and an equipment checklist for your survey.

### **1. Beverage Bottling Plants: Health Hazard**

Minimum protection: Reduced Pressure Principle Backflow Preventer.

- a. Treated boiler or air-conditioning systems.
- b. Cooling tower.
- c. Water cooled compressors or heat exchangers.
- d. Auxiliary water sources.
- e. Reservoirs and re-circulating systems (must be air-gapped).
- f. Eductor, aspirators, suction tees & venturi principle equipment.
- g. Steam connected equipment: pressure cookers, autoclaves, batch reactors.
- h. Cleaning, sterilizing & flushing lines.
- i. Rinse, dip & mixing tanks & venturi principle equipment.
- j. Unprotected hose bibs or fill-lines.
- k. Janitor sinks.
- l. Booster pump.

### **2. Canneries, Packing Houses, Reduction Plants: Health Hazard**

Minimum protection: Reduced Pressure Principle Backflow Preventer.

- a. Treated boiler or air-conditioning systems.
- b. Cooling tower.
- c. Water cooled compressors or heat exchangers.
- d. Auxiliary water sources.
- e. Reservoirs and re-circulating systems (must be air-gapped).
- f. Eductor, aspirators, suction tees & venturi principle equipment.
- g. Steam connected equipment: pressure cookers, autoclaves, batch reactors.
- h. Cleaning, sterilizing & flushing lines.
- i. Rinse, dip & mixing tanks & venturi principle equipment.

- j. Unprotected hose bibs or fill-lines.
- k. Janitor sinks.
- l. Booster pump.

### **3. Car Wash: Health Hazard**

Minimum protection: Reduced Pressure Principle Backflow Preventer.

- a. Treated boiler systems.
- b. Water cooled compressors or heat exchangers.
- c. Soap & wax education equipment.
- d. Re-circulating reclaim reservoirs (must be air-gapped).
- e. Unprotected hose bibs.
- f. Self-draining hydrants.
- g. Janitor sinks.
- h. Irrigation system.
- i. Booster pump.

### **4. Cooling Towers: Health Hazard**

Minimum protection: Approved Air-Gap Separation

- a. Chemical treatment lines – corrosion inhibitors.
- b. Fill water make-up line.

Cooling towers, usually require some treatment of the water for algae, slime, or corrosion control. A further hazard is that they are usually open to the atmosphere and subject to Legionella contamination.

### **5. Covered Gravity or Pressure Storage Tanks: Pollution Hazard**

Minimum protection: Double Check Valve Assembly

- a. Direct Connection.

This category applies only to storage tanks where the water is used for culinary and sanitary purposes.

Covered gravity tanks are most common in a multistory building where the public water system pressure will not supply the upper floors.

A pump may be used to pump the public water to a tank, usually found on the roof or in the penthouse, which then supplies water to the upper floors.

Pressure storage tanks may also be found in a multistory building where air pressure is used to force water to the upper floors instead of using a pump.

## **6. Chemical Plants: Health Hazard**

Minimum protection: Reduced Pressure Principle Backflow Preventer.

- a. Treated boiler or chiller systems.
- b. Cooling tower.
- c. Water cooled compressors or heat exchangers.
- d. Submerged inlets to tanks.
- e. Direct connection to machinery.
- f. Auxiliary water sources.
- g. Formulating, decanting & processing tanks or equipment.
- h. Extractors/precipitators.
- i. Cleaning, sterilizing & flushing lines.
- j. Eductor, aspirators, suction tees & venturi principle equipment.
- k. Rinse, dip & mixing tanks with submerged inlets.
- l. Re-circulating reclaim reservoirs/lagoons.
- m. Water cooled or hydraulic operated equipment.
- n. Washers, cookers, and flumes.
- o. Unprotected hose bibs or fill-lines.
- p. Self-draining hydrants.
- q. Janitor sinks.
- r. Irrigation system.
- s. Booster pump.

This is a very broad category and will require careful consideration of processes used in the plants. Water for manufacturing purposes is requisite for most chemical plants and is used to purge lines and clean vats and tanks, as well as for process water. Cross-connections varies with the toxicity of chemicals used. You can ask for the MSDS descriptions to determine the toxicity of a particular compound.

## **7. Film Processing Labs: Health Hazard**

Minimum protection: Reduced Pressure Principle Backflow Preventer.

- a. Submerged inlets to processing, developing & fixing tanks or trays.
- b. Automated film processing equipment.
- c. Water cooled compressors or heat exchangers.
- d. Chemical eductors, aspirators, suction tees & venturi principle equipment.
- e. Reclaim equipment.
- f. Unprotected hose bibs or fill-lines.
- g. Janitor sinks.
- h. Includes residential darkroom facilities.

## **8. Hospital: Health Hazard**

Minimum protection: Reduced Pressure Principle Backflow Preventer.

- a. Treated boiler or chiller systems.
- b. Steam generating equipment.
- c. Water cooled compressors or heat exchangers.
- d. Cooling tower.
- e. Re-circulating reservoirs or lagoons.
- f. Auxiliary water sources.
- g. Autopsy room.
- h. Mortuary.
- i. Bedpan washers, urinals, bathtubs, lavatories.
- j. Autoclaves & sterilizers.
- k. Garbage disposals or grinders.
- l. X-ray developing equipment.
- m. Eductor, aspirators, suction tees & venturi principle equipment.
- n. Laboratory equipment with water connections.
- o. Lab sinks.
- p. Specimen tanks.
- q. Pipette tube washers.
- r. Hydro-therapy equipment.
- s. Restaurant type equipment (lunchroom & cafeteria).
- t. Laundry Facility.
- u. Unprotected hose bibs.
- v. Janitor Sinks.
- w. Irrigation System.



- x. Swimming pool.
- y. Booster pump.

This category includes medical buildings, doctor's office, sanitariums, clinics, public-health centers, operatories, morgues, mortuaries and veterinary offices.

## **9. Irrigation System: Health Hazard**

Minimum protection: reduced pressure backflow preventer, or a pressure vacuum breaker if the premises is a residential property and there are no chemical additives, pumps, eductors or injection systems.

- a. Sprinkle heads.
- b. Chemical eductors or injection systems.

The hazard represented by this equipment is that the sprinkler heads can become submerged in pools of contaminated water.

## **10. Laundry: Health Hazard**

Minimum protection: Reduced Pressure Principle Backflow Preventer.

- a. Treated boiler or chiller systems.
- b. Steam generating equipment.
- c. Water cooled compressors or heat exchangers.
- d. Soap, sanitizer, bleach, and softening eductor systems.
- e. Submerged inlets to laundry equipment.
- f. Water storage tanks.
- g. Bluing & dying equipment with submerged inlets.
- h. Sewage pumps for priming, cleaning, flushing, or unclogging purposes.
- i. Unprotected hose bibs.
- j. Janitor sinks.
- k. Booster pumps.

Some of the machines or the equipment may have pumps that can pump contaminated fluids through cross-connections into the potable water system.

## **11. Marine Facilities: Health Hazards**

Minimum protection: Reduced Pressure Principle Backflow Preventer.

- a. Unprotected hose bibs at docks.
- b. Unprotected in-port water service connections.
- c. Direct connection points for ship's dockside fire protection systems.
- d. Flushing connections for shipboard sewage systems.

The actual or potential hazard to the public water system created by any marine facility or dockside-watering point must be individually evaluated.

The primary risk to the public water system is that the fire pumps or the other pumps aboard a ship can pump contaminated water into the water system.

In addition to the normal risk peculiar to dockside watering points, risks are often found at those areas where dockside-watering facilities are used in connection with marine construction, maintenance, and repair, and permanent or semi-permanent moorages.

## **12. Oil & Gas Facility: Health Hazard**

Minimum protection: Reduced Pressure Principle Backflow Preventer.

- a. Treated boiler or chiller systems.
- b. Cooling towers.
- c. Re-circulating reservoirs.
- d. Water cooled compressors or heat exchangers.
- e. Connections used to purge oil or gas from lines.
- f. Hydraulic connections used to raise the level in the tank.
- g. Hydraulic testing equipment.
- h. Unprotected hose bibs.
- i. Janitor sinks.

## **13. Metal Manufacturing: Health Hazard**

Minimum protection: Reduced Pressure Principle Backflow Preventer.

- a. Treated boiler or chiller systems.
- b. Cooling towers.
- c. Water cooled compressors or heat exchangers.
- d. Submerged inlets to tanks.

- e. Direct connections to machinery.
- f. Auxiliary water sources.
- g. Formulating, decanting & processing tanks or equipment.
- h. Extractors/precipitators.
- i. Cleaning, sterilizing & flushing lines.
- j. Plating facilities.
- k. Vats used in painting, anodizing, cleaning, stripping, or oxidizing operations.
- l. Hydraulically operated equipment.
- m. Eductor, aspirators, suction tees & venturi principle equipment.
- n. Industrial-fluid systems and lines containing cutting or hydraulic fluids.
- o. Rinse, dip & mixing tanks with submerged inlets.
- p. Re-circulating reclaim reservoirs/lagoons.
- q. Water cooled or hydraulic operated equipment.
- r. Washers, cookers, and flumes.
- s. Unprotected hose bibs or fil-lines.
- t. Self-draining hydrants.
- u. Janitor sinks.
- v. Irrigation systems.
- w. Booster pump.

#### **14. Multistory buildings: Pollution to Health Hazard**

Minimum protection: Double Check Valve Assembly to Reduced Pressure Principle Backflow Preventer.

This category maybe broadly grouped into the following categories in terms of their internal potable water systems:

- a. Using only the service pressure to distribute the potable water throughout the structure, the water is used only for culinary or sanitary facilities and with no internal potable water reservoir. In this case there could be no hazard.
- b. Using a booster pump to provide potable water.
- c. Using a booster pump to fill a covered tank from which there is a gravity feed system.

A pollution hazard evaluation is possible only if there are no cross-connections to fixtures that present a greater degree of hazard.

Considerable care must be exercised to determine if the suction-side line to these pumps is also being used as the takeoff for domestic, sanitary, laboratory, or industrial uses on the lower floors. Pollutants or contaminants from equipment supplied by the connections on the suction side of the pump may be backsiphoned during periods of heavy demand and can then be pumped throughout the building.

### **15. Paper Products Plants: Health Hazard**

Minimum protection: Reduced Pressure Principle Backflow Preventer.

- a. Treated boiler or chiller systems.
- b. Cooling towers.
- c. Water cooled compressors or heat exchangers.
- d. Submerged inlets to tanks.
- e. Direct connections to machinery.
- f. Auxiliary water sources.
- g. Cleaning, sterilizing & flushing lines.
- h. Pulp bleaching, dyeing, and processing vats.
- i. Hydraulically operated equipment.
- j. Eductor, aspirators, suction tees & venturi principle equipment.
- k. Industrial-fluid systems and lines containing cutting or hydraulic fluids.
- l. Rinse, dip & mixing tanks with submerged inlets.
- m. Re-circulating reclaim reservoirs/lagoons.
- n. Water cooled or hydraulic operated equipment.
- o. Washers, cookers, and flumes.

### **16. Plating Plants: Health Hazard to Severe Health Hazard**

Minimum protection: Reduced Pressure Principle Backflow Preventer.

- a. Treated boiler or chiller systems.
- b. Water cooled compressors or heat exchangers.
- c. Auxiliary water sources.
- d. Vats used in painting, anodizing, cleaning, stripping, or oxidizing operations.
- e. Plating solution filtering equipment with pumps and circulating lines.
- f. Formulating, decanting, & processing tanks or equipment.
- g. Extractors & precipitators.
- h. Eductor, aspirators, suction tees & venturi principle equipment
- i. Rinse, dip & mixing tanks with submerged inlets.

- j. Re-circulating reclaim reservoirs/lagoons.
- k. Water cooled or hydraulic operated equipment.
- l. Unprotected hose bibs or fill-lines.

The primary concern at this type of plant should be the presence of submerged inlets in wash, plating, or rinse tanks/vats; and the toxicity of the chemicals used in the tanks/vats.

### **17. Residential Properties: No Hazard to Health Hazard**

Minimum protection: None to Reduced Pressure Principle Backflow Preventer.

- a. Treated heating systems.
- b. Unprotected hose bibs.
- c. Underground irrigation systems.
- d. Hose connected sewer unclogging apparatus.
- e. Eductor type sump pumps.
- f. Drain line from hot water heater.
- g. Personal bidet.
- h. Submerged spray in the bathtub.
- i. Submerged hose in the laundry tray.
- j. Auxiliary water sources.
- k. Swimming pools.
- l. Fish ponds, fountains, or small pools/ponds.

### **18. Restaurants: Health Hazard**

Minimum protection: Reduced Pressure Principle Backflow Preventer.

- a. Treated boiler and chiller systems.
- b. Degreaser, soap, and sanitizer eductors at sinks.
- c. Commercial grade dishwashers.
- d. Commercial grade garbage disposals.
- e. Food grinders.
- f. Pot and pan washers.
- g. Carbonated beverage dispensers.
- h. Coffee maker.
- i. Janitor sink with eductor attached.
- j. Ice machine.
- k. Pressure cookers or steamers.
- l. Unprotected hose bibs.

m. Irrigation system.

The equipment types for this category may also be applied to grocery stores.

### **19. Restricted Facilities: Health Hazards**

Minimum protection: reduced pressure principle backflow preventer.

This applies automatically to any facility that is not readily accessible for inspection by the supplier of water.

It includes:

- a. Military installations.
- b. Some governmental installations.
- c. Factory research and development labs.
- d. Production facilities with radioactive substances areas.
- e. Quarantine facilities.

### **20. Schools: Health Hazards**

Minimum protection: Reduced pressure principle backflow preventer.

- a. Treated boiler or chiller system.
- b. Cooling tower.
- c. Auxiliary water sources.
- d. Dental office.
- e. Nurses office.
- f. Cafeteria with typical restaurant equipment.
- g. Swimming pool.
- h. Hydro-therapy equipment.
- i. Jacuzzi.
- j. Chemistry labs with typical laboratory equipment.
- k. Educational automotive or machining equipment.
- l. Greenhouse or horticultural facility.
- m. Unprotected hose bibs.
- n. Janitors sink with educator attached.
- o. Irrigation system to ballfield.

## **21. Water Hauling Equipment: Severe Health Hazard**

Minimum protection: approved air-gap separation.

- a. Submerged inlet.

Water-hauling tank truck used to fill cisterns, for dust control, for herbicide or pesticide spraying or for mobile cleaning equipment.

### **H. Evaluating Degree of Hazard Summary**

An evaluation of degree of hazard is the determination of the potential for backflow to occur and the toxicity of the substances that could backflow.

The potential for backflow to occur due to an actual or potential cross-connection is the first determination that must be made.

Then you need to evaluate the toxicity of the substances that could backflow to determine if they present a danger to the health of the water users, or will cause physical damage to the public water system, or are simply aesthetically objectionable.

The Ohio EPA recognizes four degrees of hazard:

- Pollution Hazard
- System Hazard
- Health Hazard
- Severe Health Hazard

The Ohio DOC recognizes three degrees of hazard:

- Low Hazard
- High Hazard
- Severe High Hazard with a recommendation for an approved air-gap separation.

Although the Ohio Environmental Protection Agency and the Ohio Department of Commerce have different verbiage for the various degrees of hazard, there is a correlation between the two agency degrees of hazard.

## **Section 18. Responsibility & Authority**

### **A. The responsibility for backflow prevention rests jointly with the:**

1. Supplier of Water
2. User of Water
3. Plumbing Inspection Authority'
4. Regulatory Agencies

The regulatory agencies in Ohio are the Ohio Environmental Protection Agency and the Ohio Department of Commerce.

Each has a responsibility and must carry its phase of a coordinated program in order to prevent backflow.

Backflow prevention may be divided into two areas of protection.

### **B. Protection of the Public Water Supply:**

Regulatory Authority rests in the Ohio Environmental Protection Agency:

1. Enforcement rests in the water supplier.
2. Requires a containment principle of backflow prevention.
3. BPA is installed at the water meter.

### **C. Protection of the Water User's System**

Regulatory Authority rests with the Ohio Department of Commerce (DOC)  
The Chief Plumbing Inspector

1. Enforcement rests with the Plumbing Inspection Authorities.
2. Requires the isolation principle of backflow prevention.
3. Backflow prevention Device is installed at an internal fixture.
4. Responsible for isolation devices.

### **D. Authority**

1. In Ohio there are two Regulatory Agencies that oversee the potable water supplies.
2. The Ohio Environmental Protection Agency has the authority over the public water system from the source to the service connection, which is defined in Ohio Administrative Code as the outlet side of the water meter.



3. The water supplier acts as the enforcement officer for the Ohio EPA and uses the containment principle of backflow prevention to protect the public water supply from backflow at the water meter. The containment principle BFA remains under the authority of the water supplier even if it is installed inside the building.
4. The Ohio Department of Commerce has authority over the water user's potable water system, which begins at the water meter and includes all piping and fixtures in the building.
5. The local plumbing official acts as the enforcement officer for the Ohio DOC. The plumbing official uses the isolation principle of backflow prevention to protect the consumer's water system at each fixture.
6. If the water meter is installed inside the building then the containment principle backflow preventer must be installed immediately after the water meter. If the meter is installed outside of the building then the containment principle backflow preventer is typically installed inside the building wall unless otherwise approved by the water supplier.

## **E. Responsibility**

### **The Supplier of Water**

1. The supplier of water has the primary responsibility for providing each consumer with safe and potable water. This responsibility begins at the source, includes all of the public water user. That point of delivery is defined in the Ohio Administrative Code as the service connection or the outlet side of the water meter.
2. The supplier of water must se reasonable care and vigilance to protect the public water system from hazards originating within the water user's system.
3. The courts have repeatedly refused to sustain the defense that the governmental status of municipalities and officials carries any immunity against liability for negligence in safeguarding the public health. The courts have held that a municipality that operates a water supply system has same rights as a privately owned utility but are also subject to the same liabilities. Ignorance is no excuse.
4. Although the supplier of water has no direct authority over the water user's system, the supplier of water is required to conduct periodic surveys of the water user's premises to determine if there are any cross-connections and to evaluate the water use practices.

## **The Responsibilities of the Supplier of Water**

1. Review plans for new buildings prior to construction to determine the degree of hazard to the public water system, and perform site inspections during or immediately after construction.
2. Conduct or cause to be conducted periodic surveys of the water use at existing buildings to determine the degree hazard to the public water system. Risk management.
3. Require the water user to eliminate cross-connection hazards or to protect the public water system by the installation of a containment principle backflow prevention assembly at the water meter.
4. Require the water user to have their containment principle BPA tested at the time of installation and every 12 months thereafter.

## **The Water User**

1. The water user has the dual responsibility of protecting the consumers at the premises and helping to protect the public water system from contamination originating from cross-connections within the premises.
2. The responsibility begins at the service connection and includes the entire internal water distribution system.
3. The water user is liable for any installation on his premises that could endanger the water quality of either the public or his own water distribution system.

## **Six Responsibilities of the Water User**

1. Conduct his/her own periodic surveys of the internal water system to determine if there are actual or potential cross-connections.
2. Examine all plans for new piping installations to determine the degree of hazard and must inspect the installation to ensure that the system is free of unprotected cross-connections.
3. Must protect the public system by installing containment and isolation principle backflow prevention devices where and when required.
4. Must protect the internal water distribution system by compliance with the state and local plumbing regulations.
5. Must maintain all containment principle assemblies in proper working order, and report tests and maintenance performed to the supplier of water.
6. Must maintain all isolation devices in proper working order, and report tests and maintenance performed to the local plumbing inspection authorities.

### **The Plumbing Inspection Authorities**

1. The plumbing inspection authorities have a responsibility of inspecting the water user's distribution system to ensure that all cross-connections within the premises are protected from backflow.
2. They meet this responsibility by enforcing the rules of the Ohio Board of Building Standards relating to plumbing. The current plumbing code adopted by the State of Ohio is the International Plumbing Code.
3. The plumbing inspection authorities are liable for the inspection of all cross-connections within the water user's premises prior to the building being occupied.

### **Three Responsibilities of the Plumbing Inspection Authorities**

1. Review plans for new buildings prior to construction to determine if each fixture is properly protected against backflow, and perform site inspection during or immediately after construction.
2. Require the water user to protect the internal water system by the installation of an isolation principle backflow prevention device at the fixture.
3. Require the water user to have their isolation principle PBA tested at the time of installation and every 12 months thereafter.

### **Regulatory Agencies**

1. The regulatory agencies are responsible for creating laws, rules, and regulations regarding backflow prevention. No single agency has complete authority or responsibility in Ohio from the source to the sewer. The following regulatory agencies are all in backflow prevention.

### **Ohio Environmental Protection Agency**

1. Adopts rules regarding public water supply systems and provides general supervision of the public water systems. The supplier of water is responsible for enforcing the rules of the Ohio EPA. These rules are codified in Section 3745-95 of Ohio Administrative Code.
2. The Ohio EPA and the supplier of water have authority up to the outlet side of the water meter and over all auxiliary water supplies that are interconnected with the water user's piping even if it is located somewhere within the building.

## **Ohio Department of Commerce**

1. The Ohio DOC enforces the Ohio Board of Building Standards Regulations and the Ohio Plumbing Code as they relate to internal plumbing. These rules may be administered locally, but fall under the purview of the State of Ohio Chief Plumbing Inspector. The Department of Commerce and the local plumbing officials have authority over the piping and fixtures inside the building. They enforce the rules found in the Ohio Plumbing Code.

## **Four Responsibilities of the Regulatory Agencies**

1. Establish laws, rules, and regulations for the protection of the public water system and the water user's distribution system.
2. Requires plans for new or altered plumbing installations and public water supply systems to be submitted for approval.
3. Inspect plumbing installations and public water supply systems to determine that they are in compliance with state code.
4. Requires the supplier of water and the plumbing inspection authorities to establish effective backflow prevention program.

## Section 19. Inspection, Testing, and Maintenance Procedures for Backflow Preventers

Maintenance and regular inspection of backflow preventers are integral parts of any backflow prevention program.

Responsibility for installing and maintaining the backflow preventer rests with the water consumer. Each backflow preventer must be inspected at regular intervals and records of the inspection, testing, and repairs made available to the supplier of water and/or the regulatory agency.

The supplier of water and the regulatory agency should be prepared to give technical assistance in the installation of the backflow preventer. For example, the following figures, A-1 shows proper installation of an RP in a horizontal position

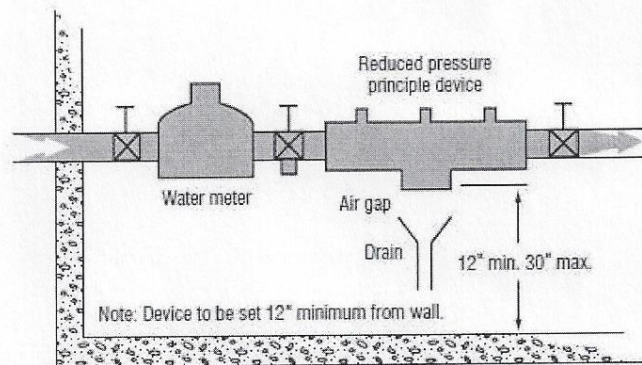

Figure A-1. Horizontal installation of a reduced pressure principle backflow prevention assembly. The clearance dimensions indicated are recommended to provide access for testing and repair.

Proper installation of an RP in a vertical position Figure A-2. Assemblies must be installed to allow access for testing and repair. Vertical installation should only be used if horizontal installation is not feasible and upon approval of the water purveyor. The assembly must also be certified effective by the manufacturer if installed in the vertical position.

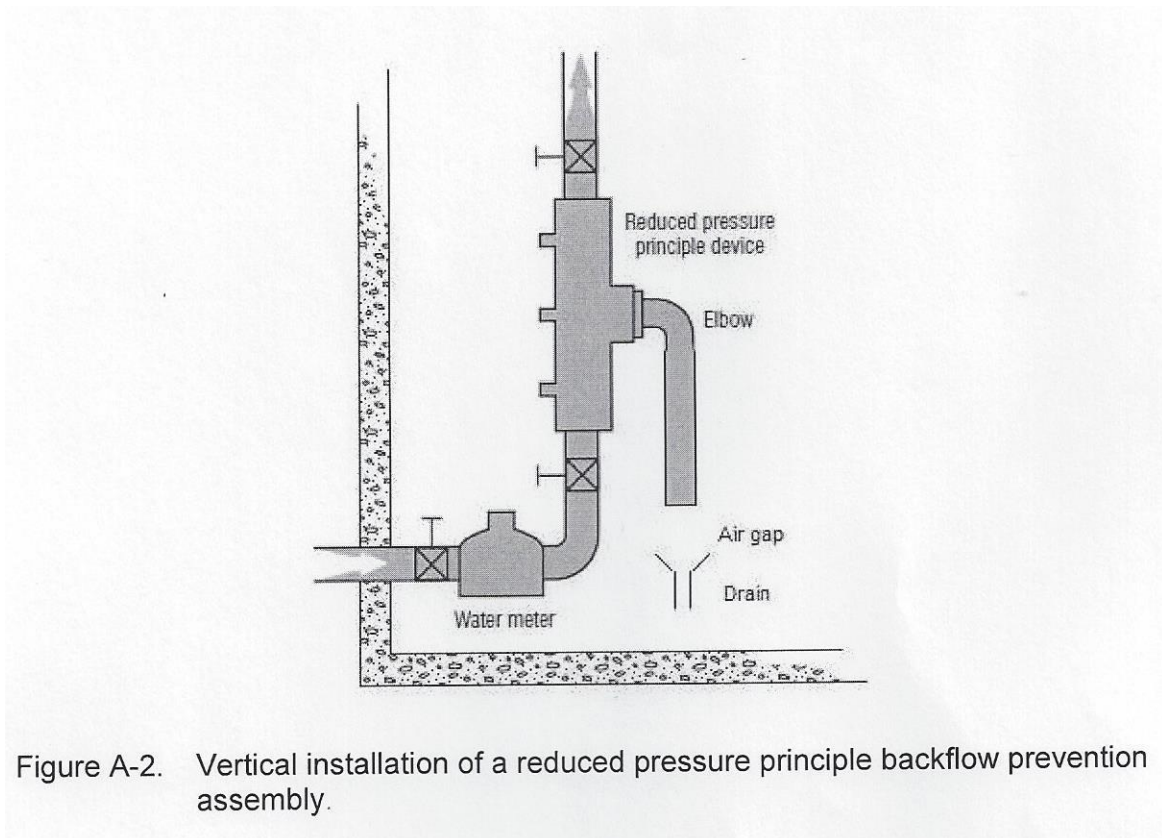

Figure A-2. Vertical installation of a reduced pressure principle backflow prevention assembly.

### A. Test Gauges:

1. A differential pressure gauge is required for testing reduced pressure backflow prevention assemblies and the newer type pressure vacuum breakers (which utilize springs for the air inlet and check valve) and also is used to test double check valve assemblies. A single pressure gauge is required for testing low suction pressure cut-off controllers and minimum pressure sustaining valves.
2. Differential pressure gauges measure the difference in pressure between two points in the system. The range of these gauges is usually limited to 15 psid (pounds per square inch differential), therefore they cannot be used to measure line pressure. They usually are of the balanced

diaphragm type which contains a pressure differential diaphragm and a magnetic drive, and are protected from excess or reverse pressure by drive stops.

3. A variety of pre-assembled test kits are available from a number of manufacturers. These test kits differ in the connections and needle valves provided, which may require some adjustment of the test procedures outlined in this appendix. It is important that the tests be thoroughly understood before any such adjustments are made.
4. Only high quality, calibrated gauges may be used. It is recommended that filter/strainers be used on all of the connecting hoses. A variety of adapter fittings are required for attaching the connector hoses to the test cocks of the various sizes of backflow prevention assemblies.
5. The test gauges are precision instruments and must be treated with care. The needle valves must be closed only finger tight or they may be irreparably damaged and have to be replaced. The gauges must be drained after each use and all valves left in the open position. Prior to the start of each test, all valves on the gauges should then be closed.
6. The gauges most commonly used to test backflow preventers are the three valve and five valve types of a pressure differential gauge. The gauge indicates pressure in pounds and two tenths of a pound as pounds per square inch differential or psid.
7. Figure A-3 provides an illustration of the components of the three-valve test gauge as used in the test procedures provided on pages 75 to 96.
8. The five-valve analog gauge works exactly the same as the three-valve analog gauge. It compares the difference between two pressures and the gauge needle indicates the difference between the two pressures. However, due to the additional valves, the test steps are slightly different although the test procedures are exactly the same.
9. Figure A-4 provides an illustration of the components of the five-valve test gauge as used in the test procedures on pages 75 to 96.

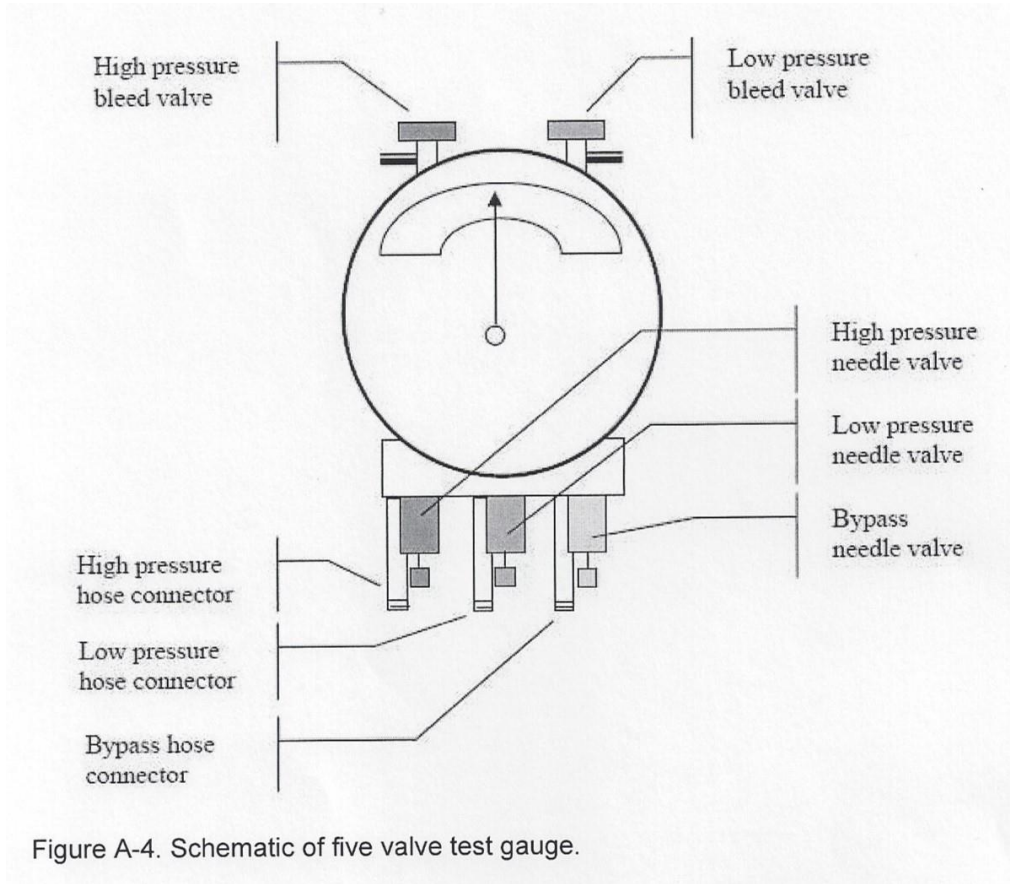
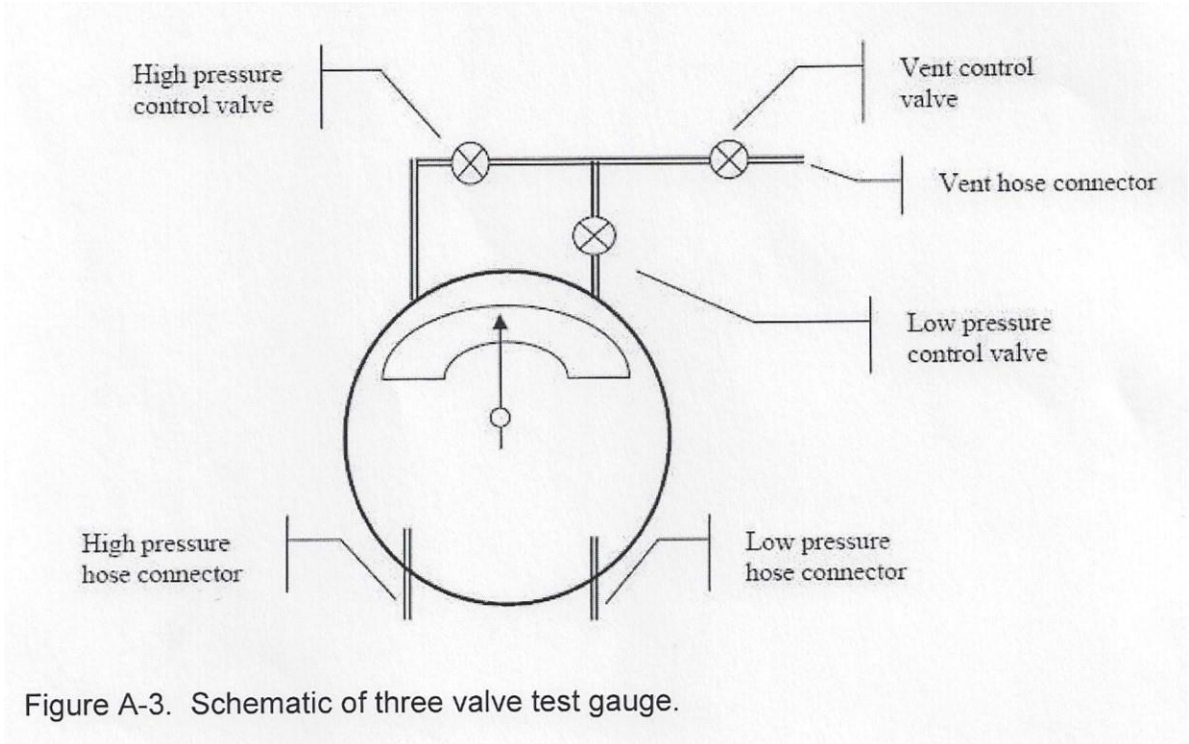



10. Other test devices have been used to test backflow prevention assemblies, such as the combination bourdon test gauges or duplex gauge. Their use is still acceptable provided the tester understands the methodology to properly apply the test methods when using these test devices.
11. The test procedures provided in this manual for the pressure vacuum breaker, the double check valve assembly and the reduced pressure principle backflow prevention assembly reference the use of either the three valve or five valve differential pressure test gauge.

## **B. Air Gap Separation**

### **Equipment Required**

A measuring tape to ascertain whether the air gap is properly installed.

### **Requirements**

1. Air gap separations shall be inspected at the time of installation and at least every twelve months thereafter by an inspector approved by the supplier of water.
2. They shall not be bypassed, or otherwise made ineffective.
3. All defects found during inspection of the air gap shall be satisfactorily corrected without delay.

### **Inspection Procedure**

1. Determine that the air gap separation provides the required minimum air gap.
2. Confirm that the air gap separation is not being bypassed.

The following form is a suggested method to record and report on the inspection of an air gap.

**Report on Inspection**  
**Air Gap Separation**

Location of Device \_\_\_\_\_.

Date Installed \_\_\_\_\_ Service No. \_\_\_\_\_.

I hereby certify that the air gap separation described above was inspected by me on \_\_\_\_\_ and the following findings were made:  
(date)

\_\_\_\_\_ Effective diameter of the supply pipe or opening.

\_\_\_\_\_ Near wall distance, if present.

\_\_\_\_\_ Height of supply opening above the flood-level rim.

\_\_\_\_\_ Required minimum air gap separation is provided.

Yes No

\_\_\_\_\_ Air gap separation is not being bypassed.

Yes No

\_\_\_\_\_ No evidence that arrangements have been made to bypass the air gap separation.

Yes No

Inspector \_\_\_\_\_  
(signature) (printed name)

**CERTIFICATION**

I hereby certify that the foregoing report is correct and that the following statement is true:

The air gap separation has been in constant use at the location during the entire prescribed interval between inspections and during that period this device was not bypassed or otherwise made ineffective.

Company \_\_\_\_\_ Signature \_\_\_\_\_.

Address \_\_\_\_\_ Print Name \_\_\_\_\_.

\_\_\_\_\_ Title \_\_\_\_\_.

\_\_\_\_\_ Date \_\_\_\_\_.

### C. Vacuum Breakers ASSE 1020

TEST POINT	MINIMUM TEST REQUIREMENT
Air Inlet Valve	The minimum opening point must be 1 psig
Check Valve	Must create a minimum 1 psig pressure loss

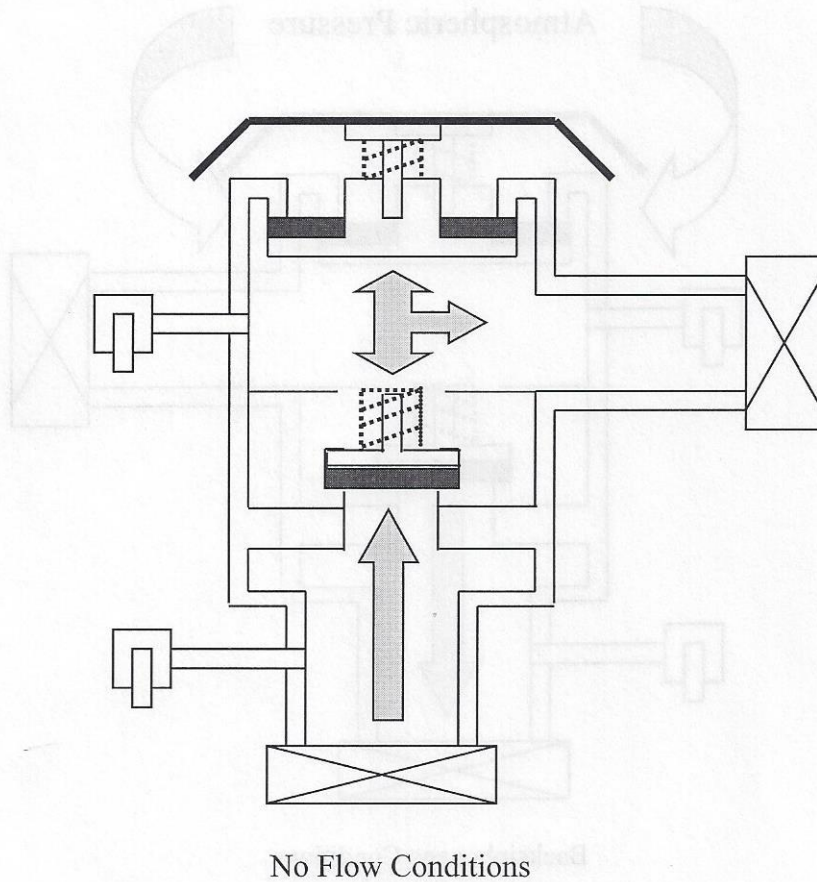

#### 1. Requirements

- a. Pressure vacuum breakers shall be routinely inspected at least every three months by the owner for visible conditions which would or could prevent the normal functioning of the device.
- b. They shall be inspected and tested for capability to prevent backsiphonage at the time of installation and at least every twelve months thereafter by an inspector approved by the regulatory agency

and/or the supplier of water whenever needed and at least every twelve months.

- c. A complete record of each device must be maintained by the owner. This shall include a comprehensive listing from purchase to retirement of all inspections, tests and repairs.
- d. They shall not be bypassed, made inoperative or removed without proper authorization.
- e. All defects found during inspection, testing or overhaul of the devices shall be satisfactorily corrected without delay.

## **2. Routine Inspection Procedure**

- a. Observe for signs of water leaks from the vent ports. Water marks or other surface stains on the outside of the body would indicate leaking and possible malfunctioning of the device.
- b. Inspect for conditions that would prevent normal functioning of the device. Cloth or other material may be wrapped around the device, covering the vent ports. The vent closing mechanism may be locked in closed position by some mechanical means that could only be revealed by removing the hood or bonnet of the vacuum breaker.
- c. Determine that the device is not subjected to backpressure under any conceivable condition. Boilers, elevated storage tanks, pumps or other pressure producing systems could cause the device to be subjected to backpressure.
- d. Inspect for proper location and position in the water system. Pressure vacuum breakers must be located at a high point, at least twelve inches above the flood or overflow levels of all equipment or outlets being supplied.
- e. Determine that the device has not been removed without proper authorization.

#### **D. Field Test Procedure – Pressure Type**

1. The field test for pressure type vacuum breakers is intended to test the capability of the device to prevent backsiphonage. The procedure for testing is as follows:

#### **E. Internal Inspection Procedure for Pressure Vacuum Breaker**

1. Inspect the valve seats for scoring or dirt accumulation which could result in leakage through the air inlet valve. The valve discs should also be checked for cracking or other indications of imperfections.
2. Observe the internal parts for any accumulation of foreign matter which could cause malfunctioning. Check to see that the guides are not fouled and that the port flow areas are not filled.

**Field Test Procedure Using Three Valve Gauge for Pressure Vacuum Breaker**  
**ASSE 1020**

**SETUP**

- a. Install hose adapters and flush test cocks #1 and #2
- b. Close all control valves on test equipment
- c. Remove the air inlet canopy

---

TEST 1:	Purpose:	To test Air Inlet Valve
	Requirements:	The Air Inlet Valve must open when the pressure in the valve body drop to 1.0 psig above atmospheric pressure, and the air inlet valve must open fully when all of the water has drained from the valve body.

Note: It is important that the test gauge be positioned at the same elevation as the vacuum breaker during test #1 in order to eliminate any effect from a water column created in the hose.

**PROCEDURE**

- a. Connect the high-pressure hose to test cock #2
- b. Slowly open test cock #2 so that you do not slam the gauge needle
- c. Open the high-pressure control valve
- d. Open the vent control valve to bleed any air from the hose and gauge
- e. Close the vent control valve
- f. Close Shut-Off Valve #2
- g. Close Shut-Off Valve #1
- h. Slightly open the low control valve to allow the water pressure in the body of the pressure vacuum breaker to fall slowly while observing the pressure differential gauge.  
You may touch (but do not push) the air inlet valve to feel for the first movement as it opens; in a quiet area you can hear the air inlet valve open.
- i. Record the pressure differential, at which the air inlet valve opened, on the test form.  
The gauge reading at the point of opening must be 1 psig or greater for the air inlet valve to pass
- j. Close the low-pressure control valve
- k. Close test cock #2 and disconnect the hose
- l. Open Shut-off Valve #1 quickly in order to reseal the air inlet valve and re-pressurize the assembly

**CONTINUE TO TEST 2**



**Field Test Procedure Using Five Valve Gauge for Pressure Vacuum Breaker**  
**ASSE 1020**

**SETUP**

- a. Install hose adapters and flush test cocks #1 and #2
  - b. Connect the high, low and bypass hoses to the gauge
  - c. Close all control valves on test equipment
  - d. Remove the air inlet canopy
- 

<b><u>TEST 1:</u></b>	Purpose:	To test Air Inlet Valve
	Requirements:	The Air Inlet Valve must open when the pressure in the valve body drop to 1.0 psig above atmospheric pressure, and the air inlet valve must open fully when all of the water has drained from the valve body.

Note: It is important that the test gauge be positioned at the same elevation as the vacuum breaker during test #1 in order to eliminate any effect from a water column created in the hose.

**PROCEDURE**

- a. Connect the high-pressure hose to test cock #2
- b. Open the high-pressure bleed valve
- c. Slowly open test cock #2 so that you do not slam the gauge needle
- d. Close the high-pressure bleed valve
- e. Close Shut-Off Valve #2
- f. Close Shut-Off Valve #1
- g. Slightly open the high-pressure bleed valve to allow the water pressure in the body of the pressure vacuum breaker to fall slowly while observing the pressure differential gauge.

You may touch (but do not push) the air inlet valve to feel for the first movement as it opens; in a quiet area you can hear the air inlet valve open.

- h. Record the pressure differential, at which the air inlet valve opened, on the test form. The gauge reading at the point of opening must be 1 psig or greater for the air inlet valve to pass.
- i. Close test cock #2 and disconnect the hose j. Open Shut-off Valve #1 quickly in order to reseal the air inlet valve and re-pressurize the assembly.

**CONTINUE TO TEST 2**



**Field Test Procedure Using Three Valve Gauge for Pressure Vacuum Breaker**  
**ASSE 1020**

<b><u>TEST 2:</u></b>	Purpose:	To test the Check Valve
	Requirements:	The Check Valve must be drip-tight in the normal direction of flow when the inlet pressure is 1.0 psig and the outlet pressure is atmospheric

**PROCEDURE**

- a. Connect the high-pressure hose to test cock #1.
- b. Open the high-pressure bleed valve.
- c. Slowly open test cock #1 so that you do not slam the gauge needle.
- d. Close the high-pressure bleed valve.
- e. Close Shut-off Valve #1.
- f. Fully open test cock #2.

This will drain the water from the body of the vacuum breaker and open the air inlet valve. When the flow from the test cock #2 stops, lift the gauge to place pressure against the check valve in the direction of flow. The pressure reading indicated on the gauge will be the pressure drop across the check valve.

- g. Record the gauge reading on the test form.  
The gauge reading must be 1 psig or greater for the check valve to pass.
- h. Close test cocks #1 and #2, then disconnect the hose.
- i. Open Shut-off Valve #1 quickly in order to seat the air inlet valve and repressurize the assembly.
- j. Open Shut-off Valve #2
- k. Re-install the air inlet canopy.
- l. Open all of the control valves to drain the water in the gauge.
- m. Remove the hose adapters.
- n. Make sure that the water is back on to the building.

**-END OF TEST PROCEDURE-**

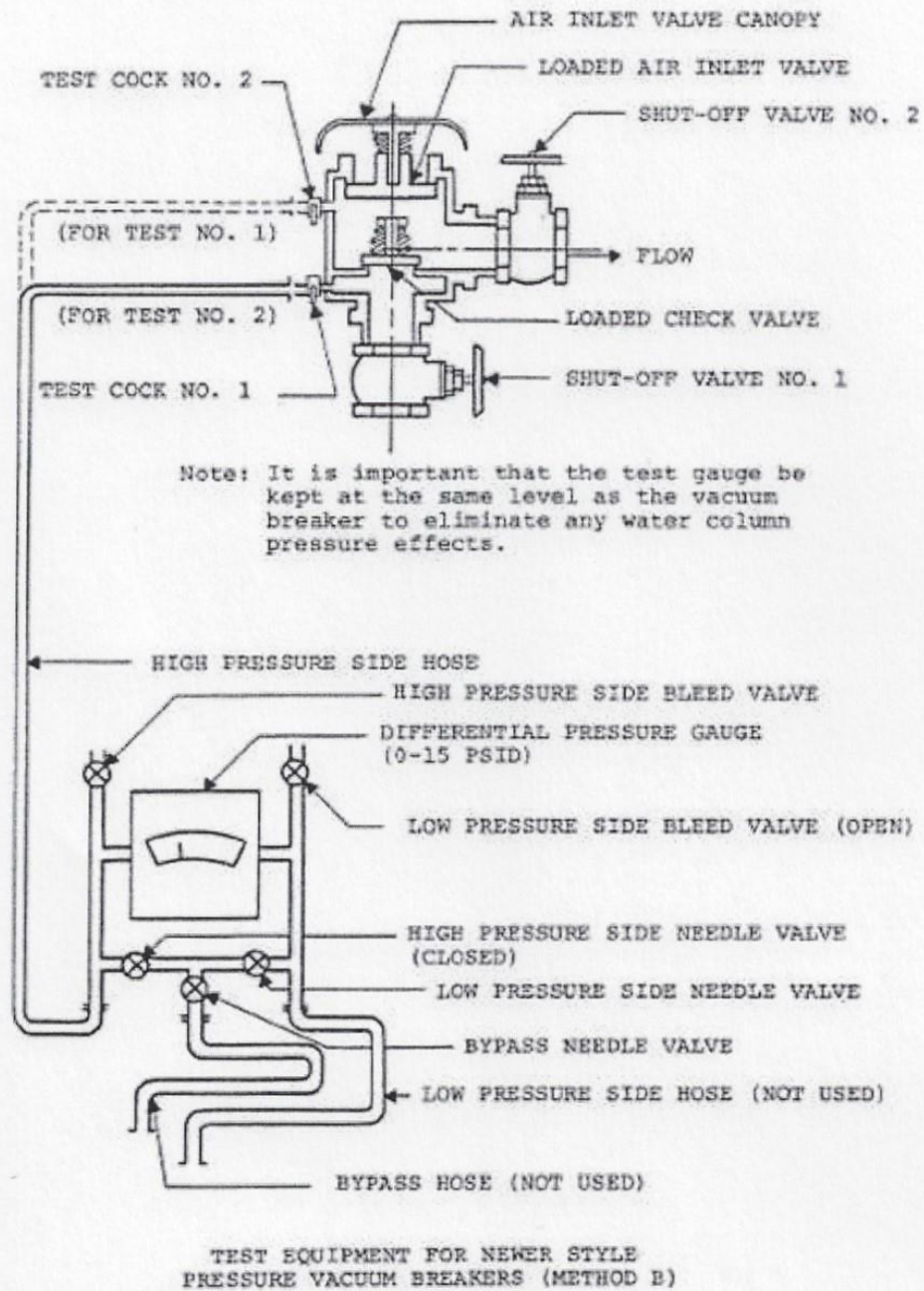
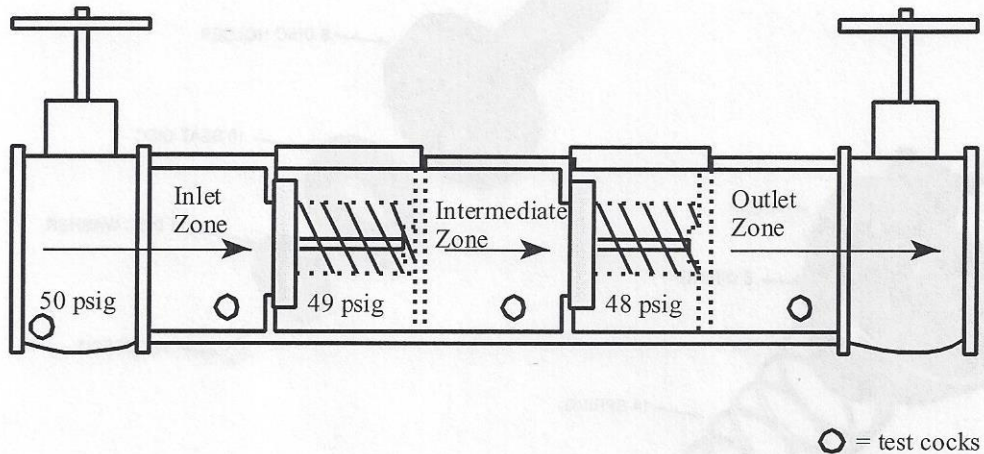

Figure A-5. Five Valve Gauge Test Equipment for Pressure Vacuum Breakers

## F. Double Check Valve Assembly ASSE 1015

### CROSS-SECTION DOUBLE CHECK VALVE ASSEMBLY – ASSE 1015



1. Under flow conditions, both checks should be open.
2. Under no flow conditions, both checks should close tightly.
3. Under backpressure or backsiphonage conditions, both checks should close tightly.

TEST POINT	MINIMUM TEST REQUIREMENT
Shut-off Valve 2	Must be drip-tight
Check valve number 1	Must create a minimum 1.0 psid pressure loss
Check valve number 2	Must create a minimum 1.0 psid pressure loss

### 1. Requirements

- a. Double check valve assemblies shall be inspected and tested for tightness at the time of installation and at least every twelve months thereafter by an inspector approved by the supplier of water.

- b. A complete record of each device must be maintained by the owner. This shall include a comprehensive listing from purchase to retirement of all tests, inspections, and repairs.
- c. They shall not be bypassed, made inoperative, or removed without proper authorization.
- d. All defects found during inspection, testing and overhaul of the device shall be satisfactorily corrected without delay.

## 2. Routine Inspection Procedure

- a. Determine that the double check valve assembly has been installed in accordance with approved plans and that it has not been relocated, removed, or bypassed without proper notification or authorization.

## 3. Field Test Procedures

- a. Equipment Required:
  - 1. 1 Pressure differential gauge
  - 2. 3 lengths of 1/4 inch high pressure hose with screw type couplings.
  - 3. 4 adapter fittings, 1/4 inch IPS by hose, brass.
  - 4. 4 IPS adapter fittings, 1/4 inch by test cock size, brass.

## Field Test Procedure Using Three Valve Gauge for Double Check Valve Assembly ASSE 1015

---

### SETUP

- a. Install hose adapters and flush test cocks #1, #2, #3, #4
  - b. Close all control valves on gauge
  - c. Close shut-off valve #2
- 

<b>TEST 1:</b>	Purpose:	To test Shut-Off Valve #2
	Requirements:	Shut-off Valve #2 must be drip-tight in order to obtain accurate results for Tests #2 and #3

### PROCEDURE

- a. Connect the high-pressure hose to test cock #1.
- b. Connect the low-pressure hose to test cock #4.
- c. Open test cock #1 then open test cock #4.
- d. Open the high control valve.
- e. Open the vent control valve to bleed any air from the hose and gauge.
- f. Close the high control valve.
- g. Open the low control valve to bleed any air from the hose and gauge, do not close low control valve.
- h. Close the vent control valve.
- i. Close the Shut-off valve #1.
- j. Open the high control valve.
- k. Observe the gauge reading, it should be zero (0 psi).

If the needle on the gauge remains zero, record Shut-off Valve #2 as holding tightly.

If the needle on the gauge rises above zero, record Shut-off Valve #2 as leaking and it must be repaired before you can continue the test. A reading above zero is an indication that there is a pressure head loss through the gauge as the water flows past the leaking Shut-off Valve #2.

- l. Open a fixture downstream of Shut-off Valve #2 to create a flow and accurately determine if Shut-off Valve #2 is holding tightly.
- m. Close all control valves on the gauge.
- n. Close test cocks #1 and #4 and disconnect the low- and high-pressure hoses.
- o. Open Shut-off Valve #1.

**CONTINUE TO TEST 2 AND 3**



j. Observe and record the gauge reading on the test form.

The gauge reading must be 1 psid or greater for the check valve #2 to pass.  
If the gauge needle reads less than 1 psid or continues to drop toward zero,  
then record check valve #2 as fail.

k. Close test cocks #3 and #4 and disconnect the low- and high-pressure hoses.

l. Open Shut-off Valve #2.

m. Open all the control valves to drain the water in the gauge.

n. Remove the hose adapters.

o. Make sure the water is back on to the building.

**-END OF TEST PROCEDURE-**







i. Observe and record the gauge reading on the test form.

The gauge reading must be 1 psid or greater for the check valve #2 to pass.  
If the gauge needle reads less than 1 psid or drops toward zero, then record  
check valve #2 as fail

j. Close test cocks #3 and #4 and slowly bleed the gauge pressure from the bleed valves.

k. Open Shut-off Valve #2.

l. Open all the control valves to drain the water in the gauge.

m. Remove the hose adapters.

n. Make sure the water is back on to the building.

**-END OF TEST PROCEDURE-**

#### 4. Internal Inspection Procedure (When necessary)

- a. Never dismantle more than one valve nor have more than one unit out of service at one time.
- b. Clean the inside of the valves thoroughly. Remove the poppet or the hinge pin and clapper and clean them. Inspect the test cocks and gauge connections and see that sediment and rust are removed.
- c. Wash the elastomer valve facing ring and replace it if it is damaged or has lost its resiliency. See that the seat is smooth and clean. Have a spare facing ring on hand.
- d. Replace the poppet or clapper. See that it seats tight and that the poppet or clapper is entirely free and capable of opening wide. A good fitting valve will make a hollow sound when the poppet or clapper is lifted slightly and dropped onto the seat.
- e. A new gasket is usually required for the valve cover. Have one on hand when making an inspection.
- f. After cleaning both valves make the regular test for tightness.
- g. Finally, expel air from valves, restore pressure, and be sure to leave both shut-off valves open.

Note: The proper equipment and considerable skill and care are required when disassembling/assembling the larger devices to avoid injury to the mechanic(s) or damage to the device. Spring loadings or clapper weights can exceed 100 pounds.

Lubricants should not be necessary for proper operation of the device, but may be sparingly used to aid in assembly. Only food grade lubricants or a pharmaceutical grade mineral oil may be used.

**G. REDUCED PRESSURE PRINCIPLE BACKFLOW PREVENTION ASSEMBLY ASSE 1013.**

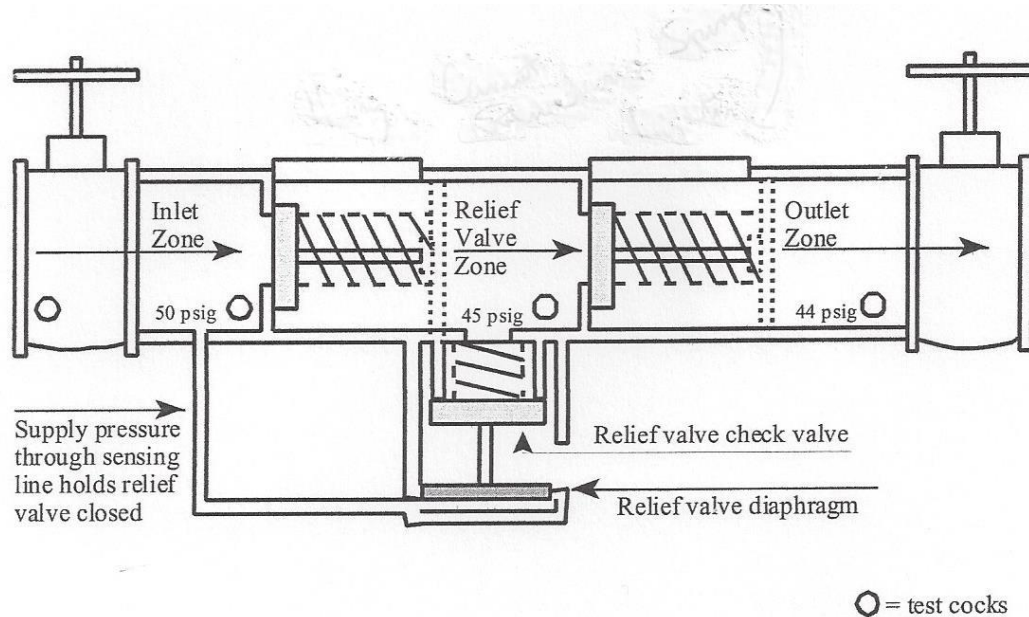

TEST POINT	MINIMUM TEST REQUIREMENT
Check valve no. 1	The minimum acceptable pressure loss is 5 psig, but to pass the test it must create a loss equal to or greater than the relief valve opening point plus 3 psig
Differential pressure relief valve	The relief valve must vent water before the pressure in the relief valve zone comes within 2 psig of the supply pressure
Check valve no. 2	Must hold tightly against backpressure
Shut-off Valve 2	Must be drip-tight

**1. Requirements**

- a. Reduced pressure principle backflow prevention assemblies shall be inspected and tested for tightness and proper operation at the time of installation and at least every twelve months thereafter by an inspector approved by the supplier of water.
- b. A complete record of each device must be maintained by the owner. This shall include a comprehensive listing from purchase to retirement of all tests, inspections and repairs.

- c.** They shall not be bypassed, made inoperative or removed without proper authorization.
- d.** All defects found during inspection, testing, or overhaul of the device shall be satisfactorily corrected without delay.

It is recommended that the owner observe the assembly at least twice a week for evidence of leakage through the relief valve and routinely inspect the backflow preventer every three months.

## **2. Routine Inspection Procedure**

- a.** Look for signs of leakage from the relief valve port.
- b.** Inspect for conditions which could prevent normal functioning of the device. The opening of the relief valve port should be examined to ascertain that it has not been plugged.
- c.** Determine that the device has been properly installed above ground or floor level, whichever is higher, and that it is protected from freezing.
- d.** Observe that any discharge from the relief valve port would be visible and that the relief valve port is not directly connected to a sewer.

## **Field Test Procedure Using Three Valve Gauge for Reduced Pressure Principle Backflow Prevention Assembly ASSE 1013**

---

### **SETUP**

- a. Install hose adapters and flush test cocks #2, #3, #4
  - b. Close all control valves on the test gauge
  - c. Close shut-off valve #2
- 

<b><u>TEST 1:</u></b>	Purpose:	To test Check Valve #1
	Requirements:	Check Valve #1 must indicate a pressure differential equal to or greater than 5 psid to continue the test

### **PROCEDURE**

- a. Connect the high-pressure hose to test cock #2.
  - b. Connect the low-pressure hose to test cock #3.
  - c. Open test cock #3.
  - d. Open test cock #2.
  - e. Open the vent control valve on the gauge.
  - f. Open the high-pressure control valve to bleed any air from the hose and gauge.
  - g. Close the high-pressure bleed valve.
  - h. Open the low-pressure control valve to bleed any air from the hose and gauge.
  - i. Close the low-pressure bleed valve.
  - j. Observe the gauge to verify that Check Valve #1 is creating a minimum pressure differential equal to or greater than 5 psid in order to continue the test. Record the reading on the test form.
- 

<b><u>TEST 2:</u></b>	Purpose:	To test Pressure Differential Relief Valve
	Requirements:	The Relief valve must maintain a pressure differential of at least 2 psid between the Relief Valve Zone and the supply pressure

### **PROCEDURE**

- a. Close the vent control valve.
- b. Open the high-pressure control valve.
- c. Slightly open the low-pressure control valve to slowly increase the water pressure in the intermediate pressure zone, the gauge needle should begin to drop toward zero and observe when water first begins to discharge from the relief port.
- d. Observe the gauge reading at which this discharge is first occurring and record the psid reading shown on the gauge.
- e. Record the Relief Valve as passed if water discharged at 2 psid or greater.

- f. Compare the gauge reading obtained for Check Valve #1 and the Relief Valve. The Check Valve #1 psid must be 3 psi or greater than the Relief Valve psid for the Check Valve #1 to pass.
- g. Close the high- and low-pressure control valves.

**CONTINUE TO TEST 3 & 4**

---

**TEST 3:**      Purpose:              To test Check Valve #2  
                  Requirements:      Check Valve #2 must hold tightly against backpressure

**PROCEDURE**

- a. Open the vent control valve.
- b. Open the high-pressure control valve to bleed any air from the hose and gauge.
- c. Close the high-pressure control valve.
- d. Open the low-pressure control valve to bleed any air from the hose and gauge.
- e. Close the low-pressure control valve.
- f. Connect the vent hose to test cock #4.
- g. Open the high-pressure control valve.
- h. While observing the gauge, open test cock #4

The gauge needle may drop slightly then should remain static if Check Valve #2 is holding tightly. If the gauge needle continues to drop downward and the relief valve starts to discharge water then Check Valve #2 is leaking.

- i. Record Check Valve #2 as either pass or fail on the test form
- 

**TEST 4:**      Purpose:              To test Shut-off Valve #2  
                  Requirements:      Shut-off Valve #2 must be drip-tight in order to obtain accurate test readings

**PROCEDURE**

- a. While observing the gauge, close test cock #2

The gauge needle may drop slightly then should remain static if Shut-off Valve #2 is drip-tight. If the gauge needle continues to drop toward zero, then Shut-off Valve #2 is leaking

- b. Open a fixture downstream of Shut-off Valve #2 to create a flow and accurately determine if Shut-off Valve #2 is holding tightly.

c. Record Shut-off Valve #2 as pass or fail on the test form.

Note: If Shut-off valve #2 is leaking, then you must repair or replace the valve and repeat all tests

d. Open Shut-off valve #2.

e. Close all test cocks.

f. Remove the high, low, and vent pressure hoses.

g. Open all control valves to drain the test gauge.

h. Remove the hose adapters from the test cocks.

i. Make sure that the water is on to the building.

**-END OF TEST PROCEDURE-**



## **Field Test Procedure Using Five Valve Gauge for Reduced Pressure Principle Backflow Prevention Assembly ASSE 1013**

---

### **SETUP**

- a. Install hose adapters and flush test cocks #2, #3, #4.
  - b. Close all control valves on the test gauge.
  - c. Close shut-off valve #2
- 

<b><u>TEST 1:</u></b>	Purpose:	To test Check Valve #1
	Requirements:	Check Valve #1 must indicate a pressure differential equal to or greater than 5 psid to continue the test

### **PROCEDURE**

- a. Connect the high-pressure hose to test cock #2.
  - b. Connect the low-pressure hose to test cock #3.
  - c. Open test cock #3.
  - d. Open the low-pressure bleed valve to bleed air from the hose and gauge do not close low-pressure bleed valve.
  - e. Open test cock #2.
  - f. Wait for the needle to stabilize, then open the high-pressure bleed valve to bleed air from the hose and gauge.
  - g. Close the high-pressure bleed valve.
  - h. Close the low-pressure bleed valve.
  - i. Observe the gauge to verify that Check Valve #1 is creating a minimum pressure differential equal to or greater than 5 psid in order to continue the test. Record the reading on the test form.
- 

<b><u>TEST 2:</u></b>	Purpose:	To test Pressure Differential Relief Valve
	Requirements:	The Relief valve must maintain a pressure differential of at least 2 psid between the Relief Valve Zone and the supply pressure

### **PROCEDURE**

- a. Open the high-pressure needle valve.
- b. Slightly open the low-pressure control valve to slowly increase the water pressure in the intermediate pressure zone, the gauge needle should begin to drop toward zero and observe when water first begins to discharge from the relief port.
- c. Observe the gauge reading at which this discharge is first occurring and record the psid reading shown.
- d. Record the Relief Valve as passed if water discharged at 2 psid or greater.



- e. Close all test cocks.
- f. Remove the high, low, and bypass hoses.
- g. Open all control valves to drain the test gauge.
- h. Remove the hose adapters from the test cocks.
- i. Make sure that the water is on to the building.

**-END OF TEST PROCEDURE-**

### **3. Internal Inspection Procedure (When necessary)**

- a.** Inspect the check valves as outlined in the internal inspection procedure for the double check valve assembly.
- b.** Clean the insides of the pressure differential relief valve thoroughly.
- c.** Inspect all internal parts for wear, corrosion, erosion or mineral build-up.
- d.** Clean or replace all parts as required.
- e.** Inspect all diaphragms and “o”-rings for wear or damage, and replace as required.
- f.** After cleaning both check valves and the pressure differential relief valve, make the regular test for tightness.

**Note:** The proper equipment and considerable skill and care are required when disassembling/assembling the larger devices to avoid injury to the mechanic(s) or damage to the device. Spring loadings or clapper weights can exceed 100 pounds.

Lubricants should not be necessary for proper operation of the device, but may be sparingly used to aid in assembly. Only food grade lubricants or a pharmaceutical grade mineral oil may be used.

Figure A-6. Five Valve Gauge Test Equipment for Reduced Pressure Principle Backflow Prevention Assemblies.

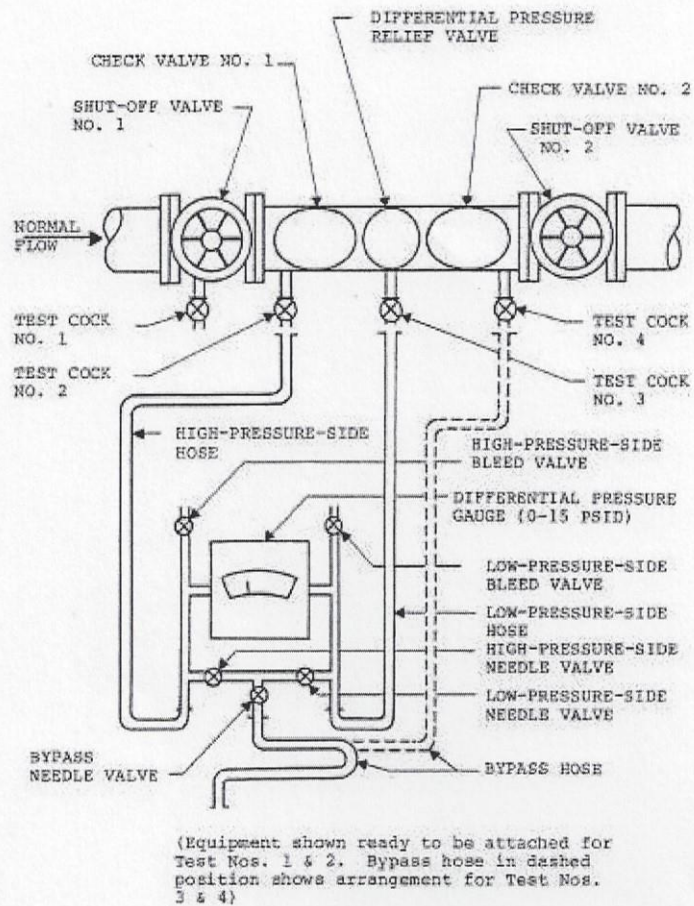

Figure A-6. Five Valve Gauge Test Equipment for Reduced Pressure Principle Backflow Prevention Assemblies

The City of Girard's required report form to record test results for Pressure Vacuum Breakers, Double Check Valve Assemblies and Reduced Pressure Principle Backflow Prevention Assemblies can be found on the following page.

**STATE OF OHIO**  
**Annual Test & Maintenance Report for Backflow Prevention Assemblies**

Facility Name: \_\_\_\_\_  
 Address: \_\_\_\_\_ Contact Person: \_\_\_\_\_

**Assembly Information**

Make: \_\_\_\_\_  
 Model: \_\_\_\_\_  
 Size: \_\_\_\_\_  
 Serial Number: \_\_\_\_\_

**Installation Information**

Containment <input type="checkbox"/>		Isolation <input type="checkbox"/>	
Meter Pit <input type="checkbox"/>	Basement <input type="checkbox"/>	Floor Number: _____	
Penthouse <input type="checkbox"/>	Boiler Room <input type="checkbox"/>	Room Number: _____	
Mechanical Room <input type="checkbox"/>	Protection Provided: _____		

Double Check Assembly			
<b>Initial Test</b>	Outlet Valve		Pass _ Fail _
	1 <sup>st</sup> Check Valve	___ psid	Pass _ Fail _
<b>Date</b>	2 <sup>nd</sup> Check Valve	___ psid	Pass _ Fail _

Reduced Pressure Assembly		
1 <sup>st</sup> Check Valve	___ psid	Pass _ Fail _
Relief Valve Opening Point	___ psid	Pass _ Fail _
2 <sup>nd</sup> Check Valve		Pass _ Fail _
Outlet Valve	Pass _	Fail _

Pressure Vacuum Breaker		
Air Inlet Valve	___ psig	Pass _ Fail _
Check Valve	___ psig	Pass _ Fail _

<b>Repairs &amp; Materials Used</b>	
-------------------------------------	--

--

--

Double Check Assembly			
<b>Re-Test After</b>	Outlet Valve		Pass _ Fail _
<b>Repairs</b>	1 <sup>st</sup> Check Valve	___ psid	Pass _ Fail _
<b>Date</b>	2 <sup>nd</sup> Check Valve	___ psid	Pass _ Fail _

Reduced Pressure Assembly		
1 <sup>st</sup> Check Valve	___ psid	Pass _ Fail _
Relief Valve Opening Point	___ psid	Pass _ Fail _
2 <sup>nd</sup> Check Valve		Pass _ Fail _
Outlet Valve	Pass _	Fail _

Pressure Vacuum Breaker		
Air Inlet Valve	___ psig	Pass _ Fail _
Check Valve	___ psig	Pass _ Fail _

**Comments:**

**TESTER CERTIFICATION:** *I hereby certify that the above data is correct and that the backflow prevention device is in proper working condition.*

Tester Name (Printed) \_\_\_\_\_ Signature \_\_\_\_\_

OTCO Certified Tester #: \_\_\_\_\_ OTCO Certified Tester Exp. Date: \_\_\_ / \_\_\_ / \_\_\_

Department of Commerce Certified Tester

Company Name \_\_\_\_\_ Ohio Certificate #: \_\_\_\_\_ Contractor #: \_\_\_\_\_ Date: \_\_\_\_\_

*I hereby certify that the above backflow prevention device has been in constant use at this location during the entire prescribed interval between test periods and during that period this device was not bypassed, made inoperative or removed without proper authorization. I further certify that I have the authority and responsibility to ensure the above.*

Owner/Officer (Printed) \_\_\_\_\_ Signature \_\_\_\_\_

Title: \_\_\_\_\_ Date: \_\_\_\_\_

## **H. INTERCHANGEABLE CONNECTION**

### **1. Requirements**

- a.** Interchangeable connections shall be inspected and their reduced pressure principle backflow prevention assemblies tested for tightness and proper operation at the time of installation and at least every twelve months thereafter by an inspector approved by the supplier of water.
- b.** They shall not be bypassed, made inoperative, or removed without proper authorization.
- c.** All defects found during inspection, testing or overhaul of the interchangeable connection shall be satisfactorily corrected without delay.

It is recommended that the reduced pressure principle backflow prevention assembly be routinely inspected by the owner at least every three months and observed for leakage from the relief port at least twice a week in accordance with the procedures given on page 93.

### **2. Inspection Procedure**

- a.** Determine that the interchangeable connector and the backflow prevention assembly have been properly installed. A separate stop valve must be installed on each piping connection. An approved reduced pressure principle backflow prevention assembly must be installed on the public water supply pipe supplying the interchangeable connection. There must be a free discharge from the tell-tale port of a four-way valve. No piping should be connected to the tell-tale port.
- b.** Confirm that the assembly has been installed in accordance with approved plans and that it has not been relocated, removed or bypassed without proper notification or authorization.
- c.** Test the reduced pressure principle backflow prevention assembly installed as part of the interchangeable connection for tightness and proper operation using the field test procedure found on page 93.

The following form is suggested to record and report inspections of interchangeable connections.

**INTERCHANGEABLE CONNECTION INSPECTION REPORT FORM**

Premises Address: \_\_\_\_\_ Company Name: \_\_\_\_\_.

Contact Name: \_\_\_\_\_ Contact Phone No: \_\_\_\_\_.

Location of Interchangeable Connection: \_\_\_\_\_

Type of Connection: 4-Way \_\_\_\_ Swing \_\_\_\_ Service Number: \_\_\_\_\_.

Meter Number: \_\_\_\_\_.

Type of Inspection: Initial \_\_\_\_ Annual \_\_\_\_ Date of Inspection: \_\_\_\_\_.

I certify that the interchangeable connection as described above was inspected by me on the date indicated and the following findings were made:

Yes \_\_\_\_ No \_\_\_\_ The interchangeable connection was found to be properly installed in accordance with the requirement of the Ohio Environmental Protection Agency and the plans as approved.

Yes \_\_\_\_ No \_\_\_\_ The interchangeable connection has not been bypassed removed, or relocated.

Yes \_\_\_\_ No \_\_\_\_ The reduced pressure principle backflow prevention device, installed as part of this interchangeable connection has been tested for tightness and proper operation (test report attached).

COMMENTS: \_\_\_\_\_  
\_\_\_\_\_  
\_\_\_\_\_

INSPECTOR: Signature: \_\_\_\_\_ Printed Name: \_\_\_\_\_.

Cert. Tester No. \_\_\_\_\_ Date: \_\_\_\_\_.

.....  
I certify that the foregoing inspection was performed on the date indicated and that the following statement is true: The interchangeable connection as described above has been in uninterrupted use during the entire prescribed interval between inspections and that during that period has not been bypassed or otherwise made ineffective.

Company Representative: (Print Name) \_\_\_\_\_ Date: \_\_\_\_\_.

Signature: \_\_\_\_\_ Title: \_\_\_\_\_.



## **I. BOOSTER PUMP LOW-SUCTION PRESSURE CUT-OFF CONTROLLER**

### **1. Requirements**

- a. Booster pump low-suction pressure cut-off controllers (and minimum pressure sustaining valves, if installed) shall be inspected and tested for proper operation at the time of installation and at least every twelve months thereafter.
- b. A complete record of each installation must be maintained by the owner. This shall include a comprehensive listing from purchase to retirement of all tests, inspections and repairs.
- c. They shall not be bypassed, made inoperative, or removed without proper authorization.
- d. All defects found during inspection, testing or overhaul of the devices shall be satisfactorily corrected without delay.

### **2. Inspection Procedure**

- a. Determine that the device has been properly installed. The suction sensing line must be connected upstream from the booster pump. The minimum pressure sustaining valve, if provided, must be installed downstream from the booster pump. See Figure A-7 for proper installation.
- b. Confirm that the device has not been relocated, removed, bypassed or made inoperative without proper notification or authorization.
- c. Confirm that the water department seal on the suction pressure sensing line is intact.

### **3. Field Test Procedure**

- **Equipment Required:**
  - 1 Pressure measurement gauge (i.e. bourdon, diaphragm or mechanical pressure gauge).
  - 1 length of 1/4 inch high pressure hose with screw type couplings.
  - 1 adapter fitting, 1/4 inch IPS by hose, brass.
  - 1 IPS adapter fitting, 1/4 inch by test cock size, brass.

The suction pressure sensing line for the booster pump should be equipped with an isolation valve (with a water department seal) and a test cock.

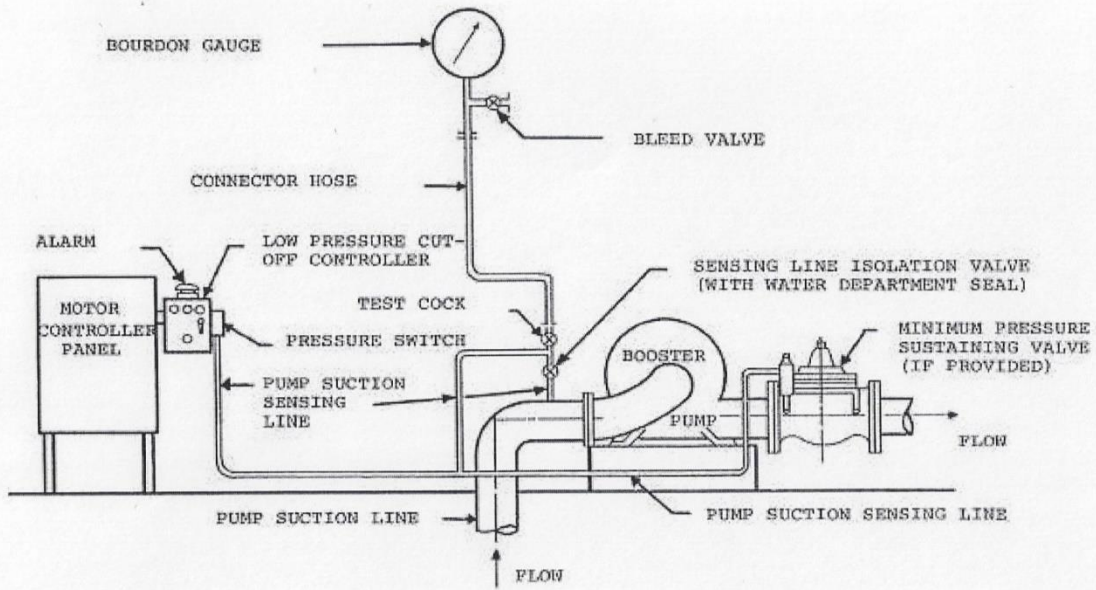

Figure A-7. Test Equipment for Low Suction Pressure Cut-off Devices and Low Suction Throttling Valve and Variable Speed Suction Limiting Control

## Test No. 1

Purpose: To test the operation of the low suction pressure cut-off device.

Requirement: The low pressure cut-off device shall operate to shut-off the booster pump within 30 seconds when the pressure in the pump suction sensing line drops to 10 psig or less.

Steps:

- a. Open and then close the test cock to flush out any sediment, scale or debris; then attach the adapter fitting.
- b. Attach the gauge hose to the test cock.
- c. Open the test cock.
- d. Bleed the air from the hose and gauge using the bleed valve; then close the bleed valve.
- e. Start the booster pump. It may be desirable to have the owner's representative or booster pump tester do this.
- f. Remove the water department seal from the isolation valve on the pump suction sensing line and close the isolation valve.
- g. Carefully open the bleed valve and slowly lower the pressure in the sensing line to 12 psig; then close the bleed valve and hold this pressure for 30 seconds.
- h. Using the bleed valve as in step g, lower the pressure in the sensing line by 1 psi increments until the pump shuts off within 30 seconds.
- i. Record the pressure reading at which the pump shuts off. This pressure must be 10 psig or greater.

## Test No. 2

Purpose: To test the operation of the low suction throttling valve, if installed.

Requirement: The low suction throttling valve shall operate to maintain the booster pump suction pressure above 10 psig under all flow conditions.

- a. Steps: While performing Test No. 1, above, if the booster pump is equipped with a low suction throttling valve, observe the valve setting indicator to determine if the valve is closing in response to the simulated suction pressure. The low suction throttling valve control should reduce the pump

speed down to minimum levels per manufacturer as the suction sensing line drops below 10 psig.

- b. Reopen the sensing line isolation valve. Observe the pressure gauge to determine that the pressure returns to line pressure.
- c. Observe that the booster fire pump returns to operating normally.
- d. Turn of the booster pump and return all motor control circuits to their normal settings.
- e. Return all valves to their normal positions.
- f. Close the test cock, depressurize the test gauge and remove the hose and adapter fittings.
- g. Seal the sensing line isolation valve in the open position.

For booster pumps used in fire suppression systems (fire pumps), the backflow prevention methods (assemblies and minimum suction pressure sustaining methods), should be tested upon a completion of the annual forward flow fire pump test, in accordance with State Fire Code and the code's referenced National Fire Protection Association (NFPA) 20 standard. The forward fire flow test ensures that the backflow prevention methods are not interfering with operation of the fire pump (such as valves sticking or malfunctioning), however, the integrity of the backflow assembly to hold during backflow conditions or proper operation of the minimum suction pressure method under low pressure conditions must still be verified.

The following forms are suggested to record and report inspection and test results for the low suction pressure cutoff controller and the minimum pressure sustaining valve installed on booster pumps and fire suppression system booster pumps (fire pumps) and the variable speed suction control on fire pumps. Backflow prevention assemblies must be tested in accordance with their respective test methods outlined in this manual and results recorded on the suggestion form.

## TEST REPORT FOR LOW SUCTION PRESSURE CUT-OFF CONTROLLER ON BOOSTER PUMP

Premises Address: \_\_\_\_\_ Company Name: \_\_\_\_\_  
 Contact Name: \_\_\_\_\_ Contact Phone No: \_\_\_\_\_  
 Type of Controller: Fire Pump \_\_\_\_\_ Domestic Booster Pump \_\_\_\_\_  
 Pressure Sustaining Valve \_\_\_\_\_ Manuf \_\_\_\_\_  
 Model Number \_\_\_\_\_ Serial Number \_\_\_\_\_  
 Type of Inspection: Initial \_\_\_\_\_ Annual \_\_\_\_\_ Date of Inspection: \_\_\_\_\_

\*\*\*\*\*

Yes	No	
_____	_____	Found the sensing line seal intact
_____	_____	Found the normal power light (green) on

### MANUAL START

_____	_____	Low suction light (red) comes on when suction pressure reaches 10 psig
_____	_____	The alarm sounds after a minimum 30 second delay
_____	_____	The pump shuts off immediately after the low suction pressure alarm sounds
_____	_____	The pump has automatic restart when the sensing line is recharged

### AUTOMATIC START

_____	_____	Low suction light (red) comes on when suction pressure reaches 10 psig
_____	_____	The alarm sounds after a minimum 30 second delay
_____	_____	The pump shuts off immediately after the low suction pressure alarm sounds
_____	_____	The pump has automatic restart when the sensing line is recharged

### RESET PUMP

_____	_____	Opened outlet valve at pump discharge
_____	_____	Pump restarted in manual start mode
_____	_____	Pump restarted in automatic start mode
_____	_____	Resealed sensing line valve in open position

I certify that the low pressure cut-off controller test as described above was performed by me on the date indicated and the findings were as indicated.

INSPECTOR: Signature \_\_\_\_\_ Printed Name \_\_\_\_\_  
 Cert. Tester No. \_\_\_\_\_ Date \_\_\_\_\_

\*\*\*\*\*

I certify that the inspection was performed on the date indicated and that the following statement is true: The low suction pressure cut-off controller has been in uninterrupted use during the interval between inspections and during that period has not been bypassed or otherwise made ineffective.

Company Representative: (Print Name) \_\_\_\_\_ Date \_\_\_\_\_  
 Signature \_\_\_\_\_ Title \_\_\_\_\_

**TEST REPORT FOR LOW SUCTION THROTTLING VALVE ONLY ON BOOSTER OR FIRE PUMP**

Premises Address: \_\_\_\_\_ Company Name: \_\_\_\_\_  
 Contact Name: \_\_\_\_\_ Contact Phone No: \_\_\_\_\_  
 Type of Controller: Fire Pump \_\_\_\_\_ Booster Pump \_\_\_\_\_  
 Throttling Valve \_\_\_\_\_ Manuf \_\_\_\_\_  
 Model Number \_\_\_\_\_ Serial Number \_\_\_\_\_  
 Type of Inspection: Initial \_\_\_\_\_ Annual \_\_\_\_\_ Date of Inspection: \_\_\_\_\_

\*\*\*\*\*

Yes	No	
_____	_____	Found the sensing line seal intact
_____	_____	Found the normal power light (green) on

MANUAL or AUTOMATIC START

_____	_____	Low suction throttling valve indicator showing valve closing to throttle flow and throttling action free from abnormalities
_____	_____	Low suction throttling valve indicator shows closed position at 10 psig
_____	_____	The throttling valve opens fully when the sensing line is recharged and return to full flow is free from abnormalities.

RESET PUMP

_____	_____	Opened outlet valve at pump discharge
_____	_____	Pump restarted in manual start mode
_____	_____	Pump restarted in automatic start mode
_____	_____	Resealed sensing line valve in open position

I certify that the low suction throttling valve test as described above was performed by me on the date indicated and the findings were as indicated.

INSPECTOR: Signature \_\_\_\_\_ Printed Name \_\_\_\_\_  
 Cert. Tester No. \_\_\_\_\_ Date \_\_\_\_\_

\*\*\*\*\*

I certify that the inspection was performed on the date indicated and that the following statement is true: The low suction throttling valve has been in uninterrupted use during the interval between inspections and during that period has not been bypassed or otherwise made ineffective.

Company Representative: (Print Name) \_\_\_\_\_ Date \_\_\_\_\_  
 Signature \_\_\_\_\_ Title \_\_\_\_\_

**TEST REPORT FOR VARIABLE SPEED SUCTION LIMITING CONTROL ONLY ON BOOSTER FIRE PUMP**

Premises Address: \_\_\_\_\_ Company Name: \_\_\_\_\_  
 Contact Name: \_\_\_\_\_ Contact Phone No: \_\_\_\_\_  
 Type of Controller: Fire Pump \_\_\_\_\_  
 Speed Control System (Min Speed) \_\_\_\_\_ Manuf \_\_\_\_\_  
 Model Number \_\_\_\_\_ Serial Number \_\_\_\_\_  
 Type of Inspection: Initial \_\_\_\_\_ Annual \_\_\_\_\_ Date of Inspection: \_\_\_\_\_

\*\*\*\*\*

Yes	No	
_____	_____	Found the sensing line seal intact
_____	_____	Found the normal power light (green) on

MANUAL or AUTOMATIC START

_____	_____	Variable speed suction limiting control slowed down pump driver to reduce flow and free from abnormalities
_____	_____	Variable speed suction limiting control reduces pump driver speed to minimum rating of manufacturer at 10 psig
_____	_____	The pump operates at normal speed when the sensing line is recharged and return to full flow is free from abnormalities.

RESET PUMP

_____	_____	Opened outlet valve at pump discharge
_____	_____	Pump restarted in manual start mode
_____	_____	Pump restarted in automatic start mode
_____	_____	Resealed sensing line valve in open position

I certify that the variable speed suction limiting control test as described above was performed by me on the date indicated and the findings were as indicated.

INSPECTOR: Signature \_\_\_\_\_ Printed Name \_\_\_\_\_

Cert. Tester No. \_\_\_\_\_ Date \_\_\_\_\_

\*\*\*\*\*

I certify that the inspection was performed on the date indicated and that the following statement is true: The minimum pressure sustaining valve has been in uninterrupted use during the interval between inspections and during that period has not been bypassed or otherwise made ineffective.

Company Representative: (Print Name) \_\_\_\_\_ Date \_\_\_\_\_

Signature \_\_\_\_\_ Title \_\_\_\_\_

## **J. CROSS-CONNECTION CONTROL SURVEY AND ONSITE INVESTIGATION FORMS**

The following cross-connection control survey and onsite investigation forms can be useful in accessing cross-connection control and backflow prevention needs for various service connections through the type of water use practices typically seen onsite. These forms can help the purveyor of water's representative to assess typical hazards and document backflow preventers that are in place or the need for them. These forms (except for the residential dwelling form) were taken from the Ohio Department of Commerce, Division of Industrial Compliance's, Manual of Backflow Prevention & Cross-Connection Control.



# CROSS-CONNECTION CONTROL SURVEYS

This form is intended for use as a generic survey form:

Company Name:							
Address:							
Type of Business:							
Contact Person:							
Contact Person's Phone Number:							
Meter Number:							
Meter Size:							
Existing Backflow Preventer Installed	Yes	No	Size	Manufacturer	Model	Serial Number	Date Last Tested

HEATING
<input type="checkbox"/> Forced Air
<input type="checkbox"/> Electric
<input type="checkbox"/> Solar
<input type="checkbox"/> Boiler
<input type="checkbox"/> Chemically Treated
<input type="checkbox"/> Make-up Water From City Water
<input type="checkbox"/> Feed from Chemical Feed Tank
<input type="checkbox"/> ASSE 1013 Installed at Make-up

KITCHEN
<input type="checkbox"/> Dishwasher <input type="checkbox"/> ASSE 1001 Installed
<input type="checkbox"/> Soap Eductor <input type="checkbox"/> ASSE 1001 Installed
<input type="checkbox"/> Garbage Disposal <input type="checkbox"/> ASSE 1001 Installed
<input type="checkbox"/> CO2 Dispenser <input type="checkbox"/> ASSE 1032 Installed
<input type="checkbox"/> Ice Machine <input type="checkbox"/> Air-Gap at Drain Line
<input type="checkbox"/> Hose Bibs <input type="checkbox"/> ASSE 1011 Installed
<input type="checkbox"/> Other
<input type="checkbox"/> Other
<input type="checkbox"/> Other

MISC EQUIPMENT
<input type="checkbox"/> Hose Bibs <input type="checkbox"/> ASSE 1011
<input type="checkbox"/> Eductor <input type="checkbox"/> ASSE 1001
<input type="checkbox"/> Aspirator <input type="checkbox"/> ASSE 1001
<input type="checkbox"/> Lab Faucet <input type="checkbox"/> ASSE 1001
<input type="checkbox"/> Shampoo Hose <input type="checkbox"/> ASSE 1001
<input type="checkbox"/> Wax Eductor <input type="checkbox"/> ASSE 1001
<input type="checkbox"/> Thermal Expansion Tank <input type="checkbox"/> Yes <input type="checkbox"/> No
<input type="checkbox"/> Other
<input type="checkbox"/> Other

COOLING
<input type="checkbox"/> None
<input type="checkbox"/> Forced Air
<input type="checkbox"/> Chiller
<input type="checkbox"/> Cooling Tower
<input type="checkbox"/> Chemically Treated
<input type="checkbox"/> Make-up Water From City Water
<input type="checkbox"/> Feed from Chemical Feed Tank
<input type="checkbox"/> ASSE 1013 Installed at Make-up
<input type="checkbox"/> Air-Gap at Make-up

THERAPY/POOLS/TANKS/RESERVOIRS
<input type="checkbox"/> Sitz/ Sonic Bath <input type="checkbox"/> ASSE 1001 Installed
<input type="checkbox"/> Jacuzzi <input type="checkbox"/> Air-Gap at Make-Up Line
<input type="checkbox"/> Whirlpool <input type="checkbox"/> Air-Gap at Make-Up Line
<input type="checkbox"/> Fountain <input type="checkbox"/> Air-Gap at Make-Up Line
<input type="checkbox"/> Irrigation <input type="checkbox"/> ASSE 1013 Installed
<input type="checkbox"/> Comm Laundry <input type="checkbox"/> ASSE 1001 Installed
<input type="checkbox"/> Swimming Pool <input type="checkbox"/> ASSE 1013 Installed <input type="checkbox"/> Air-Gap at Make-Up Line
<input type="checkbox"/> Wash, Dip, or Rinse Tanks <input type="checkbox"/> Air-Gap at Make-Up Line
<input type="checkbox"/> Plating or Coolant Tanks <input type="checkbox"/> Air-Gap at Make-Up Line
<input type="checkbox"/> Other
<input type="checkbox"/> Other

AUXILIARY WATER
<input type="checkbox"/> Well/Cistern <input type="checkbox"/> Yes <input type="checkbox"/> No
<input type="checkbox"/> Tower <input type="checkbox"/> Yes <input type="checkbox"/> No
<input type="checkbox"/> Reservoir <input type="checkbox"/> Yes <input type="checkbox"/> No
<input type="checkbox"/> Interconnected <input type="checkbox"/> Yes <input type="checkbox"/> No
<input type="checkbox"/> 4-Way/Swing <input type="checkbox"/> Yes <input type="checkbox"/> No
<input type="checkbox"/> Domestic Pump LPS Serial Num. <input type="checkbox"/> With LPS
<input type="checkbox"/> Fire Pump LPS Serial Num. <input type="checkbox"/> With LPS
Backflow Preventer on Fire <input type="checkbox"/> No ASSE _____
Model #of Device
Serial Number

Comments: \_\_\_\_\_

Survey by: \_\_\_\_\_ Date: \_\_\_\_\_

Company: \_\_\_\_\_ Company Phone Number: \_\_\_\_\_

## CROSS-CONNECTION CONTROL SURVEYS

This form is intended for use in a car wash type facility:

Company Name							
Premises address:							
Contact Person:							
Contact Person's Phone Number:							
Meter Number:							
Meter Size:							
Meter Location:							
Existing Backflow Preventer Installed	Yes	No	Size	Manufacturer	Model	Serial Number	Date Last Tested

FACILITY	FIXTURE	Y/N	MIN FIXTURE PROTECTION	Y/N
Car Wash Truck Wash Detailing Shop	Hot water heater		Air gap at T&P valve drain line	
	Soap eductor for wash heads		Vacuum breaker upstream of feed line	
	Wax eductor for wash heads		Vacuum breaker upstream of feed line	
	Utility sink w/ detergent eductor		Vacuum breaker at hose connection or faucet	
	Hose bib		Non-removable vacuum breaker	
	Chemically treated boiler		Reduced pressure assembly on make-up line	
	Chemically treated air conditioning		Reduced pressure assembly on make-up line	
	Drinking Fountains		Air gap & non-self draining	
	Coffee, tea, or hot chocolate machine		Air gap at fill line	
	Sanitary facilities		Air gap at fixtures	
	Recycled wash or rinse reservoir		Air gap at reservoir make-up line	
	Irrigation system		Reduced pressure assembly or Pressure vacuum breaker	
	Murdock type hydrants		Non-self draining if used for sanitary or culinary purposes - Hose bib vacuum breaker if not used for sanitary or culinary purposes	
	Auxiliary water not connected to city water line (tank, reservoir, well, lagoon)		Reduced pressure assembly at water meter	
	Auxiliary water connected to city water line (tank, reservoir, well, lagoon)		Requires Ohio EPA approval; four-way valve or swing connector	
	Backflow preventer, check valve or pressure regulator at meter		Thermal expansion device	
	Other		SEE THE BACK OF THIS FORM	

Comments: \_\_\_\_\_  
 \_\_\_\_\_  
 \_\_\_\_\_  
 \_\_\_\_\_

Survey by: \_\_\_\_\_ Date: \_\_\_\_\_  
 Company: \_\_\_\_\_ Company Phone Number: \_\_\_\_\_

## CROSS-CONNECTION CONTROL SURVEYS

---

This form is intended for use at a medical facility:

Company Name							
Premises address:							
Contact Person:							
Contact Person's Phone Number:							
Meter Number:							
Meter Size:							
Meter Location:							
Existing Backflow Preventer Installed	Yes	No	Size	Manufacturer	Model	Serial Number	Date Last Tested

FACILITY	FIXTURE	Y/N	MIN FIXTURE PROTECTION	Y/N
Hospital	Hot water heater		Air gap at T&P valve drain line	
	Water softening equipment		Air gap or inline vacuum breaker if controlled fill	
Clinic	Chemically treated boiler		Reduced pressure assembly on make-up line to boiler	
Doctor's Office	Chemical feed lines to boiler		Reduced pressure assembly on make-up line to chemical feed reservoirs	
	Chemically treated air conditioning		Reduced pressure assembly on make-up line to chiller or tower	
Dentist's Office	Chemical feed line to air conditioning		Reduced pressure assembly on make-up line to chemical feed reservoirs	
	Potable water booster pump		Low-suction pressure cut-off controller	
	Utility sink w/ detergent dispenser		Vacuum breaker at hose connection or faucet	
	X-ray developing machine		Air gap or reduced pressure assembly	
	Autopsy table		Vacuum breaker on faucet at hydro-aspirator	
	Autopsy room sink		Vacuum breaker if treaded faucet	
	Whirlpool, Sitz Bath, Hydro-Therapy equipment		Air gap at fill line	
	Bedpan washer		Vacuum breaker	
	Gooseneck lab faucets		Laboratory faucet backflow preventer	
	Ice machine & chests		Air gap at drain line	
	Hose bib		Non-removable vacuum breaker	
	Sanitary facilities		Air gap at fixtures	
	Irrigation system		Reduced pressure assembly or PVB	
	Auxiliary water not connected to city water line (tank, reservoir, well, lagoon)		Reduced pressure assembly at water meter	
	Auxiliary water connected to city water line (tank, reservoir, well, lagoon)		Requires Ohio EPA approval; four-way valve or swing connector	
	Other		SEE THE BACK OF THIS FORM	

Comments: \_\_\_\_\_

Survey by: \_\_\_\_\_ Date: \_\_\_\_\_

Company: \_\_\_\_\_ Company Phone Number: \_\_\_\_\_

## CROSS-CONNECTION CONTROL SURVEYS

This form is intended for use in a restaurant type facility:

Company Name							
Premises address:							
Contact Person:							
Contact Person's Phone Number:							
Meter Number:							
Meter Size:							
Meter Location:							
Existing Backflow Preventer Installed	Yes	No	Size	Manufacturer	Model	Serial Number	Date Last Tested

FACILITY	FIXTURE	Y/N	MIN FIXTURE PROTECTION	Y/N
Restaurant Cafeteria Lunchroom Kitchen Food Processing	Hot water heater		Air gap at T&P valve drain line	
	Detergent feed to dishwasher		Vacuum breaker upstream of feed line	
	Booster heater to dishwasher		Air gap at drain line	
	Dish rinse unit with flex hose		Vacuum breaker or air gap	
	Sink spout detergent eductor		Vacuum breaker	
	Utility sink w/ detergent dispenser		Vacuum breaker at hose connection or faucet	
	Pot & pan washer w/ submerged inlet		Vacuum breaker	
	Garbage disposal w/ direct connection		Vacuum breaker	
	Garbage can washer, submerged jet		Vacuum breaker or rinse line 6" above rim	
	Ice machine & chests		Air gap at drain line	
	Hose bib		Non-removable vacuum breaker	
	Post mix carbonated beverage machine		Dual check w/ atmospheric vent	
	Coffee, tea or hot chocolate machine		Air gap at fill line	
	Chemically treated boiler		Reduced pressure assembly on make-up line	
	Chemically treated air conditioning		Reduced pressure assembly on make-up line	
	Sanitary facilities		Air gap at fixtures	
	Irrigation system		Reduced pressure assembly or Pressure vacuum breaker	
	Murdock type hydrants		Non-self draining if used for sanitary or culinary purposes - Hose bib vacuum breaker if not used for sanitary or culinary purposes	
	Drinking Fountains		Air gap & non-self draining	
	Auxiliary water not connected to city water line (tank, reservoir, well, lagoon)		Reduced pressure assembly at water meter	
Auxiliary water connected to city water line (tank, reservoir, well, lagoon)		Requires Ohio EPA approval; four-way valve or swing connector		
Backflow preventer, check valve or pressure regulator at meter		Thermal expansion device		
Other		SEE THE BACK OF THIS FORM		

Comments: \_\_\_\_\_

Survey by: \_\_\_\_\_ Date: \_\_\_\_\_

Company: \_\_\_\_\_ Company Phone Number: \_\_\_\_\_

## CROSS-CONNECTION CONTROL SURVEYS

---

This form is intended for use for a fire protection system:

Company Name							
Premises address:							
Contact Person:							
Contact Person's Phone Number:							
Meter Number:							
Meter Size:							
Meter Location:							
Existing Backflow Preventer Installed	Yes	No	Size	Manufacturer	Model	Serial Number	Date Last Tested

FACILITY	FIXTURE	Y/N	MIN FIXTURE PROTECTION	Y/N
Fire Protection System	Limited area sprinkler (copper)		Check valve	
	Limited area sprinkler (black iron)		Double check valve assembly	
	Fire protection system, wet, no chemicals added		Double check detector check assembly	
	Fire protection system, wet, chemicals added		Reduced pressure detector check assembly	
	Fire protection system, Foamite		Reduced pressure detector check assembly	
	Fire protection system, dry		Check valve on riser prior to pressurized system	
	Fire hydrants, non-self draining		Double check detector check assembly	
	Fire hydrants, self draining		Reduced pressure detector check assembly	
	Antifreeze leg, propylene glycol		Reduced pressure detector check assembly	
	Antifreeze leg, ethylene glycol		Air gap at make-up line	
	Jockey pump only, no chemicals added		Double check detector check assembly	
	Jockey pump only, chemicals added		Reduced pressure detector check assembly	
	Fire protection Booster pump, no chemicals added		Double check detector check assembly & Low-suction pressure cut-off controller	
	Fire protection Booster pump, chemicals added		Reduced pressure detector check assembly & Low-suction pressure cut-off controller	
	Auxiliary water not connected to fire protection system (tank, tower, reservoir, well, lagoon)		Reduced pressure detector check assembly	
	Auxiliary water connected to fire protection system (tank, tower, reservoir, well, lagoon)		Requires Ohio EPA approval; a reduced pressure detector check assembly and a four-way valve or swing connector	
Other		SEE THE BACK OF THIS FORM		

Comments: \_\_\_\_\_  
 \_\_\_\_\_  
 \_\_\_\_\_

Survey by: \_\_\_\_\_ Date: \_\_\_\_\_  
 Company: \_\_\_\_\_ Company Phone Number: \_\_\_\_\_

## CROSS-CONNECTION CONTROL SURVEYS

This form is intended for use at a residential dwelling:

Owner Name:  
 Premises Address:  
 Contact Person:  
 Contact Phone:  
 Meter Number:  
 Meter Size:  
 Meter Location:  
 Existing Containment  
 Backflow Preventer  
 Installed:

YES	NO	Size	Manufacturer	Model	Serial Number	Date Last Tested

Check box that describes water use at residence:	Indicate type of backflow preventer installed on plumbing system (i.e., dual check, double check assembly, reduced pressure assembly, pressure vacuum breaker, hose bibb vacuum breaker, low pressure cutoff controller, air gap)
<input type="checkbox"/> Typical indoor water usage such as bathrooms, household laundry or dishwashing appliances, and outside water faucets/hose bibs.	
<input type="checkbox"/> Private well or cistern supplying property	
<input type="checkbox"/> Connection to underground lawn sprinkler/irrigation system	
<input type="checkbox"/> Connection into fire sprinkler system	
<input type="checkbox"/> Connection into a swimming pool or hot tub	
<input type="checkbox"/> Connection to a boiler	
<input type="checkbox"/> Booster pump	
<input type="checkbox"/> Home-based business (if checked, describe):	
<input type="checkbox"/> Other	

Comments \_\_\_\_\_  
 \_\_\_\_\_  
 \_\_\_\_\_  
 \_\_\_\_\_

Survey by: \_\_\_\_\_ Date: \_\_\_\_\_

Designee Affiliation: \_\_\_\_\_ Designee Phone Number: \_\_\_\_\_

## **K. Instructions for Completing Annual Survey for Auxiliary Water Systems**

Introduction an approved backflow preventer shall be installed on each service connection serving any customer that has an auxiliary water system, unless the supplier of water determines, on a case by-case basis, that the installation of an approved backflow preventer on a service connection is not required. This decision must take into consideration several risks which are described below. The public water system is required to conduct or cause to be conducted an inspection at least every twelve months to certify that no connection or means of connection has been created between the public water system and the auxiliary water system.

“Auxiliary water system” means any water system on or available to the premises other than the public water system. The “Annual Survey for Auxiliary Water Systems” is intended to be used by public water systems or their representatives during an inspection for documentation purposes and to help evaluate if the alternative to installation of an approved backflow preventer is appropriate. This survey may be used for both the initial and annual surveys. The survey form consists of three sections to help ensure the collection of pertinent information. The instructions provide an explanation for each section of the survey. It is the responsibility of the public water system to make the final determination if the alternative to the installation of an approved backflow preventer will be permitted.

Completing the Survey The survey is designed to direct the surveyor in such a manner as to address all the risk factors that must be reviewed in accordance with Ohio Administrative Code (OAC) rule 3745-9504(C)(2)(a). These risk factors include, but are not limited to, the past history of cross connections being established or re-established on the premises, the ease or difficulty of connecting the auxiliary water system with the public water system on the premises, the presence or absence of contaminants on the adjacent real property or other risk factors.

The opening paragraph must be completed to include the water system name, date and address of the premises served by the public water system. You may want to include additional site information such as account number or other identifiers for tracking purposes.

Potential Contaminant Source Inventory: A table has been designed to determine if any potential contaminant sources, that represent a backflow hazard, are present on the real property or premises. Real property refers to the land surrounding the premises and is owned or controlled by the consumer of water. “Premises” is defined in the Ohio Administrative Code as any building, structure, dwelling or

area containing plumbing or piping supplied from a public water system. If any potential contaminant source, including an auxiliary water system, is connected to the public water system or otherwise contained on the premises, an appropriate backflow preventer is required by OAC rule 3745-95-02, unless the actual or potential cross connections are abated or controlled to the satisfaction of the supplier of water.

Example Table

Potential Contaminant Source	Present (Y/N) on		Connected to PWS or Auxiliary System (AS)	Comments
	Adjacent Property	Premises		
Feed lot/ livestock holding area/barnyard	Y	N	PWS <input type="checkbox"/> AS <input checked="" type="checkbox"/>	Barn with horses
Irrigation system	Y	Y	PWS <input type="checkbox"/> AS <input checked="" type="checkbox"/>	Control valving within the house served by PWS.

In the above example the barn connected to the auxiliary system would not necessitate the need for a backflow preventer on the service line. However, the irrigation system on the premises would require a backflow preventer be installed on the service connection serving the house in accordance with OAC rule 3745-95-02. This is due to the auxiliary water system containing a portion of its plumbing within the premises even though there is no direct connection.

**Auxiliary Water System Information:** Questions #2 and #3 are intended to evaluate the ease or difficulty in establishing a cross-connection between the auxiliary water system and the public water system. There is no minimum separation distance established by the Ohio Administrative Code and must be determined by the public water system on a case-by-case basis. A consistent approach is recommended. Tap-to-tap connections have occurred in the past with the use of a garden hose. This fact may help in establishing minimum separation requirements between the auxiliary water system and the public water system. A drawing should be developed during the initial survey that indicates the location of any auxiliary water system(s) and the distance(s) from the premises. This drawing should be reviewed during subsequent annual surveys to ensure no changes have been made that would necessitate the need for the installation of a backflow preventer.



**Past Problems/Ease of Establishing a Cross-connection:** Questions #4 through #7 are intended to identify past problems and further evaluate the ease of establishing a cross-connection. If any of these questions are answered “Yes” then it is recommended a backflow preventer be required on the service line unless appropriate corrective actions have been taken as determined by supplier of water.

The surveyor has the option of either requiring or not requiring the installation of a backflow preventer as a result of the information collected through the survey. If a backflow prevention method or backflow preventer is required, the type should be determined and documented on the survey form. A space has been provided for the surveyor’s comments. This area can be used to justify the decisions made or to note the required corrective actions necessary to allow the option not to install a backflow preventer.

The supplier of water should maintain records of all surveys for a sufficient length of time to document the history of each auxiliary water system. A minimum of five years is required by Ohio EPA for the annual surveys. The inventory records must be kept indefinitely, as long as they remain applicable.

## Annual Survey for Auxiliary Water Systems

(Name of public water system) \_\_\_\_\_ hereby certifies that on (date) \_\_\_\_\_ the factors listed below have been evaluated during an on-site survey at (address) \_\_\_\_\_ and have been taken into consideration in determining the need for the installation of a backflow preventer. This evaluation encompasses the premises served by the (Name) \_\_\_\_\_ Public Water System and an auxiliary water system on the real property that is owned or under control of the consumer adjacent to the premises.

1. Check all of the potential contaminant sources that are present and complete the following table<sup>1</sup>:

Potential Contaminant Source	Present (Y/N) on		Connected to PWS or Auxiliary Water System (AS)	Comments (Include description of backflow preventer or method.)
	Adjacent Property	Premises		
Boiler/hot water building heat with chemical treatment			PWS <input type="checkbox"/> AS <input type="checkbox"/>	
Swimming pool			PWS <input type="checkbox"/> AS <input type="checkbox"/>	
Feed lot/livestock holding area/barnyard			PWS <input type="checkbox"/> AS <input type="checkbox"/>	
Irrigation system			PWS <input type="checkbox"/> AS <input type="checkbox"/>	
Herbicide/pesticide mixing			PWS <input type="checkbox"/> AS <input type="checkbox"/>	
Is there a business on the property that utilizes water for anything other than potable purposes? If so, what?			PWS <input type="checkbox"/> AS <input type="checkbox"/>	
Other potential backflow hazard(s).			PWS <input type="checkbox"/> AS <input type="checkbox"/>	
Explain:				

<sup>1</sup>If any potential contaminant source is connected to the PWS without an acceptable isolation device or contained on the premises then an appropriate backflow preventer may be required by OAC rule 3745-95-02. By definition, if there is a connection to the public water system, the potential contaminant source is on the premises.

2. List all auxiliary water systems. Include a drawing of the auxiliary water systems and show the distance auxiliary water systems are from all structures, property lines and locations of any items listed above.

3. What is the minimum distance between the public water system piping and the auxiliary water system?

4. Yes  No  Is there any reason to believe the physical separation has been tampered with or compromised in any way? If yes, describe:

5. Yes  No  Have unprotected cross-connections ever occurred? If yes, describe. Include dates of occurrence.

6. Yes  No  Is there a temporary or permanent means available on the premises for the purpose of cross-connecting the auxiliary water system with the public water system? If yes, describe:

7. Yes  No  Is plumbing from an auxiliary water system inside any buildings, structures, dwellings or areas which are served by the public water system? If yes, describe:

Survey Results:

- The following approved method or device is required on each service connection:
  - An air gap;
  - A reduced pressure principle backflow prevention (RP) assembly; or
  - A double check valve assembly (DCVA);

OR

- A backflow preventer on each service connection is not required.

Surveyor Comments:

---

---

---

---

---

---

---

---

Surveyor (print): \_\_\_\_\_

Surveyor Signature: \_\_\_\_\_

Date: \_\_\_\_\_

This survey must be maintained by the supplier of water for at least 5 years.

## **L. Cross-Connection Education Program Requirements and Recommended Learning Objectives**

### **Educational Program Requirements:**

The requirement to develop and implement a cross-connection education program is only required if a public water system decides to offer the alternative to the installation of an approved backflow preventer under Ohio Administrative Code (OAC) rule 3745-95-04. If the alternative is offered then OAC rule 3745-95-04(C)(2)(e) requires that a cross-connection education program be developed and implemented to inform all consumers about the dangers of cross-connections and how to eliminate them.

Recommended learning objectives have been established to assist in the development of a more comprehensive cross-connection educational program. In addition, Ohio EPA-DDAGW has developed an educational brochure that can be used by a public water system to address the recommended learning objectives.

Even if a public water system does not intend to offer the alternative to the installation of a backflow preventer for auxiliary water systems, it is recommended that an outreach effort be made to educate the consumers about the dangers of cross-connections. Education is considered an integral part of any backflow prevention program.

The method of implementation of a cross-connection education program is not specified by rule but may include: mail, posting on the Internet, public meetings, hand delivery, publication in newspaper(s), and inclusion in the Consumer Confidence Report or public service announcements. Educational materials may include brochures, fact sheets, posters, audio and video recordings, and presentations. It is intended that the educational program be implemented in such a manner as to reasonably reach all consumers particularly those that have or potentially have an auxiliary water system available to their property.

### **Recommended learning objectives:**

1. To provide a basic understanding of backflow, the associated dangers and the importance of prevention.
2. To provide the consumer an elementary understanding of common conditions that could result in a backflow hazard and what constitutes a cross-connection.

3. To provide a consumer with sufficient information to make an informed decision as it applies to cross-connections when considering plumbing modifications.
4. To inform the consumer of their rights and the rules, regulations and policies that govern backflow prevention, including the penalties associated with creating a cross-connection.
5. See EPA Backflow Prevention and Cross-Connection Control Pamphlet for this education.

If a potential or actual cross-connection contamination hazard is identified, the customer will be required to eliminate the hazard and/or install an appropriate backflow preventer at the service connection and/or at the hazard.

#### Special Conditions

##### Auxiliary Water Systems

###### What is an auxiliary water system?

It is any water system on or available to your property other than the public water system. Used water or water from wells, cisterns or open reservoirs that are equipped with pumps or other sources of pressure, including gravity are examples.

###### What protection is required?

- The auxiliary water system must be completely separated from water supply plumbing served by a public water system; and
- An approved backflow preventer must be installed at the service connection (where the public water system connects to the customer's plumbing system).

OR

- The auxiliary water system must be eliminated.

###### Are there exceptions?

At their discretion, the water supplier may waive the requirement for a backflow preventer at the service connection if all the following conditions are met:

- All components of the auxiliary water system, including pumps, pressure tanks and piping, are removed from the premises, which are defined as all buildings, dwellings, structures or areas with water supply plumbing connected to the public water system.

- The possibility of connecting the auxiliary water system to the water supply plumbing is determined by the water supplier to be extremely low.
- No other hazards exist.
- The customer enters into a contract with the water supplier, as described below.

The contract will require the customer:

- To understand the potential hazard of a cross-connection.
- To never create a cross-connection between the auxiliary water system and the public water system.
- To allow an inspector to survey their property for hazards as long as the contract is in effect.
- To face loss of service and other penalties if the contract is violated.

The water supplier must perform an annual inspection of the customer's contract-regulated property to verify the conditions have not changed, which would warrant installation of a backflow preventer. The water supplier must, by law, do everything reasonably possible to protect the water system from contamination.

##### Booster Pumps

###### What is the concern?

Booster pumps connected to plumbing systems or water mains can cause backsiphonage by reducing the water mains. The following requirements are in place to help prevent backsiphonage:

- Booster pumps, not used for fire suppression, must be equipped with a low suction cut-off switch that is tested and certified every year;
- Alternately, when a booster pump is necessary for one-, two- and three-family dwellings, it is preferred that the booster pump draw from a surge tank filled through an air gap; and

- Booster pumps, used in a fire suppression system, must be equipped with either a low suction throttling valve on the discharge side or be equipped with a variable speed suction limiting control system. Low-pressure cut-off devices will suffice for fire pumps installed prior to August 8, 2008, until a significant modification is warranted, at which point the minimum pressure sustaining method must be updated. Each of these methods must be tested and certified each year.

##### Contacts

###### Need more information?

Questions concerning backflow prevention and cross-connection control may be directed to your local water department or to your local Ohio EPA District Office at the following numbers:

Northwest District	(419) 352-8461
Northeast District	(330) 963-1200
Southwest District	(937) 285-6357
Southeast District	(740) 385-8501
Central District	(614) 728-3778

Questions regarding internal plumbing in the home may be directed to your local plumbing authority or to the Ohio Department of Commerce, Plumbing Administrator, at (614) 644-3153.

John Kasich, Governor  
Craig W. Butler, Director

Ohio EPA is an Equal Opportunity Employer  
Printed on Recycled Paper



## Backflow Prevention and Cross-Connection Control

Protecting our Public Water System

August 2015



Division of Drinking and Ground Waters  
P.O. Box 1049  
Columbus, Ohio 43216-1049  
(614) 644-2752  
[www.epa.ohio.gov](http://www.epa.ohio.gov)

Front of pamphlet.

#### What is a cross-connection?

Any physical connection created between a possible source of contamination and any drinking water system piping.

#### What is backflow?

It is the flow through a cross-connection from a possible source of contamination back into the drinking water system. It occurs when a cross-connection is created and a pressure reversal, either as backsiphonage or backpressure, occurs in the water supply piping.

#### Why be concerned?

- ALL cross-connections pose a potential health risk.
- Backflow can be a health hazard for your family or other consumers if contaminated water enters your water supply plumbing system and is used for drinking, cooking or bathing. Chemical burns, fires, explosions, poisonings, illness and death have all been caused by backflow through cross-connections.
- Backflow occurs more often than you think.
- You are legally responsible for protecting your water supply plumbing from backflow that may contaminate drinking water, either your own or someone else's. This includes complying with the plumbing code and not creating cross-connections.

#### What causes backsiphonage?

Backsiphonage occurs when there is a loss of pressure in a piping system. This can occur if the water supply pressure is lost or falls to a level lower than the source of contamination. This condition, which is similar to drinking from a glass with a straw, allows liquids to be siphoned back into the distribution system.

#### What causes backpressure?

Backpressure occurs when a higher opposing pressure is applied against the public water system's pressure. This condition allows undesirable gases or liquids from another system to enter the drinking water supply. Any pumping system (such as a well pump) or pressurized system (such as steam or hot water boilers) can exert backpressure when cross-connected with the public water system.

#### What can I do?

- Be aware of and eliminate cross-connections.
- Maintain air gaps. Do not submerge hoses or place them where they could become submerged.
- Use hose bib vacuum breakers on fixtures (hose connections in the basement, laundry room and outside).
- Install approved, testable backflow preventers on lawn irrigation systems.
- Do not create a connection between an auxiliary water system (well, cistern, body of water) and the water supply plumbing.

#### What are some common backflow hazards that threaten the homeowner and other consumers?

- Hose connections to chemical solution aspirators to feed lawn and shrub herbicides, pesticides or fertilizers.
- Lawn irrigation systems.
- Chemically treated heating systems.
- Hose connections to a water outlet or laundry tub.
- Swimming pools, hot tubs, spas.
- Private and/or non-potable water supplies located on the property.
- Water-operated sump drain devices.
- Feed lots/livestock holding areas or barnyards fed through pipes or hoses from your water supply plumbing.

#### What are examples of cross-connection and backflow scenarios?

- Soapy water or other cleaning compounds backsiphon into the water supply plumbing through a faucet or hose submerged in a bucket or laundry basin.
- Pool water backsiphons into the water supply plumbing through a hose submerged in a swimming pool.
- Fertilizers/pesticides backsiphon into the water supply plumbing through a garden hose attached to a fertilizer/pesticide sprayer.
- Chemicals/pesticides and animal feces drawn into the water supply plumbing from a lawn irrigation system with submerged nozzles.
- Bacteria/chemicals/additives in a boiler system backsiphon into the water supply plumbing.
- Unsafe water pumped from a private well applies backpressure and contaminates the public water supply through a connection between the private well discharge and the potable water supply plumbing.

#### What must be done to protect the public water system?

The public water supplier must determine potential and actual hazards. If a hazard exists at a customer's public water supply service connection, the customer will be required to install and maintain an appropriate backflow preventer\* at the meter and/or at the source of the hazard.

\*Check with your water supplier to verify which backflow preventer is required before purchase or installation.

#### Who is responsible?

In Ohio, the responsibility for preventing backflow is divided. In general, state and local plumbing inspectors have authority over plumbing systems within buildings while Ohio EPA and water suppliers regulate protection of the distribution system at each service connection.

Water customers have the ultimate responsibility for properly maintaining their plumbing systems. It is the homeowner's or other customer's responsibility to ensure that cross-connections are not created and that any required backflow preventers are tested yearly and are in operable condition.

#### What is the law?

Ohio Administrative Code Chapter 3745-95 requires the public water supplier to protect the public water system from cross-connections and prevent backflow situations. The public water supplier must conduct cross-connection control inspections of their water customers' property to evaluate hazards. Local ordinances or water department regulations may also exist and must be followed in addition to state regulations.

Back of pamphlet.

## **M. Recommended Agreement Language<sup>1</sup>**

### **OAC rule 3745-95-04(C)(2)(b)**

#### **Alternative to Installation of an Approved Backflow Preventer on Auxiliary Water System**

##### **General Requirements for Consumer Agreement:**

Any agreement intended to achieve compliance with OAC rule 3745-95-04(C)(2)(b) must contain language which specifies the penalties, including those set forth in OAC rule 3745-95-08, for creating a connection between the public water system and the auxiliary water system. Definitions of terms such as premises, real property, consumer's water system, auxiliary water system, cross-connection, etc., should be clearly defined.

##### **Suggested Language to Include in Consumer Agreement:**

No person shall install or maintain a water service connection to any premises where actual or potential cross-connections to a public water system or a consumer's water system may exist unless such actual or potential cross-connections are abated or controlled to the satisfaction of {the supplier of water}.

- (A) No person shall install or maintain a connection between a public water system or consumer's water system and an auxiliary water system.
- (B) Those consumer's that have an auxiliary water system as defined in OAC rule 3745-95-01 shall install an approved backflow preventer on the service line to each premises on the consumer's real property, except:
  - 1) Where {the supplier of water} determines, on a case-by-case basis, that the installation of an approved backflow preventer on a service connection is not required in consideration of factors including, but not limited to, the past history of crossconnections being established or re-established on the premises, the ease or difficulty of connecting the auxiliary water system with the public water system on the premises, the presence or absence of contaminants on the property or other risk factors; and
  - 2) The consumer signs an agreement not to create a connection between the public water system and the auxiliary water system and all associated penalties including but not limited to, discontinuance of service for failure to comply with the conditions of the agreement; and



3) Permits {the supplier of water} or an appointed representative the right to enter upon reasonable notification the consumer's property and premises for the purpose of conducting an inspection at least every twelve months to certify that no connection or means of connection has been created between the public water system and the auxiliary water system.

(C) Water service will be denied or discontinued, after reasonable notice to the occupant thereof, the water service to any premises wherein any backflow preventer required is not installed, tested and maintained in a manner acceptable to the {the supplier of water}, or if it is found that the backflow preventer has been removed or by-passed, or if an unprotected cross-connection exists on the premises, or if {the supplier of water} personnel, or authorized representative, is denied entry to determine compliance with backflow requirements.

(D) Water service to such premises shall not be restored until the consumer has corrected or eliminated such conditions or defects in conformance with all applicable rules and regulations, and to the satisfaction of {the supplier of water}.

(E) Additional provisions established by the supplier of water.

<sup>1</sup>Language equivalent to paragraphs A, C & D are required and paragraph B is recommended. The recommended language may need to be modified or supplemented depending on the public water system ordinances, policies, rules, regulations or user agreements. Any agreement or language developed for the intended use for compliance with OAC rule 3745-95-04(C) should be reviewed and approved by the public water system's legal counsel.

## **N. METHOD FOR ACCOMPLISHING PERIODIC SURVEYS AND INVESTIGATIONS OF EXISTING SERVICE CONNECTIONS**

The following guidance can be used to assist a PWS in determining how to fulfill the periodic survey and investigations requirement in OAC Rule 3745-95-03. Surveys may consist of a paper questionnaire completed by the consumer or supplier of water and/or reviewing of plans/permits. An investigation includes a physical onsite inspection.

1. At a minimum, an investigation must be conducted for each service connection where a likely hazard exists. These onsite investigations must occur every five years.
2. To achieve these onsite investigations, at least a sampling of active service connection for all categories of water users should be investigated every year to confirm whether or not a new or increased hazard is present and to properly address the added risk. Consider the following methodology:
  - A. Categorize service connections by type (i.e., commercial, industrial, institutional, residential) and further by water-use practice tendencies (i.e., restaurants, car washes, manufacturing type, apartment building). Standard Industrial codes, or what is now called the North American Industry Classification System (NAICS), as provided by state and federal government agencies, may be used to assist in categorizing types of water users. Each business is assigned a code through the classification system. These codes can be found online by conducting a search. One listing can be found at: <http://www.census.gov/eos/www/naics/>.
  - B. Select a subset of each type of water user and conduct the onsite investigations of them to represent the categories of users.
  - C. Determine if any changes in water use practices have occurred or an increase in the degree of hazard is possible. For example, changes in water use practices can consist of: a new process/chemical used where water provides for dilution and the hazard increased; a booster pump was added; or an irrigation system was installed.
    1. If results indicate the possibility that the degree of hazard has increased, the supplier of water must ensure the proper level of protection against backflow is provided.

2. If an onsite investigation shows no change in the degree of hazard, further action is not necessary at that time.
3. In lieu of conducting onsite investigations of the consumers' premises likely to have a hazard, the water purveyor can document, in writing, a different methodology to identify and address, on an on-going basis, new or increased, actual or potential, hazards to the water supply. Survey questionnaires can be used or triggers to help identify when a consumer's premises will require an onsite investigation. If a likely hazard exists, an onsite investigation is required to ensure the risk is mitigated.
  - A. Surveys may consist of a paper or electronic questionnaire completed by the consumer or supplier of water. The questionnaire must inquire about water use practices, connections to plumbing and types of backflow prevention on plumbing and should be tailored to include common hazards typically found at the type of premises. Review of plans can also be used.
  - B. Triggers can include notification from a licensing authority that a change in water use practice has occurred at a premises. Where they exist, collaboration with other licensing agencies, including but not limited to, local building, zoning, health, and fire protection, which are often notified when changes in water use practices are proposed, is strongly recommended. In addition, where the water purveyor has jurisdiction, events such as requests for a larger or additional meter, or a new or additional service line, would warrant an onsite investigation.

An onsite inspection is required if a change in water use practice likely represents a new or increased hazard. The approach taken should be one that is deemed necessary to determine whether or not changes in water use practices have occurred, cross-connections have been created, and the appropriate level of backflow protection is in place.

4. In lieu of conducting an on-site investigation of each residential premises without a likely hazard, the supplier of water may institute an on-going educational campaign to inform consumers of common backflow hazards created during residential water use and provide a reporting mechanism for suspected cross-connections. An education campaign may use local media and advertising resources, but must also include information

delivered, either electronically or hard copy, to each residential service connection at least annually.

5. Periodic surveys and investigations are intended to supplement the initial assessment, which is completed by the supplier of water when providing a public water system service connection to the premises. Periodic surveys and investigations do not take the place of testing and inspection requirements found in other sections of OAC 3745-95. An opportunity does exist, however, to conduct periodic surveys and investigations at the time of testing and inspection for those premises having existing containment protection.

## **Section 20. Written Notifications**

This section contains some of the possible written notifications that will be used by the City of Girard Water Department Backflow Administrator for enforcement, acknowledgement, and notifying water consumers about surveys needed, any changes to the City of Girard Backflow program, any changes in the administrator and most current contacts, letter to all approved certified plumbers and BF testers, and any other needs of the program, to keep the City of Girard Water Source safe.

Use the templates to contact the appropriate persons as needed.

**City of Girard**  
**Water Distribution Department**  
**Backflow Division**  
**100 W. Main St.**  
**Girard, OH. 44420**

**SURVEY NEEDED**

Date

RE: Cross-connection Control Survey At:

(Premise Address)

Dear Sir or Madam:

On June 11, 1990, the Council of the City of Girard passed Ordinance Number 6191-90 providing for water quality protection and cross-connection control.

The Public Health Council of the Department of Commerce, State of Ohio, during its meeting of April 15, 1972, adopted new regulations EP-5-01 to EP-5-10 inclusive of the Ohio Sanitary Code, relative to backflow prevention and cross-connection control in public water systems. These regulations became effective July 1, 1972 were adopted by the Ohio Environmental Protection Agency as Chapter 3745-95 of the Ohio Administrative Code and affect both new and existing services.

In compliance with the above laws and regulations, the City of Girard Water Distribution Department Backflow Division is required to make periodic surveys and investigations of water use practices within the consumer's premises. The purpose of these surveys is to determine whether there are actual or potential cross-connections through which contaminants could backflow into the public water system, and, if necessary, to prescribe the type of backflow preventer required.

Enclosed is a survey to be filled out and returned to the said address above or through e-mail for this purpose. If you have any trouble or problems completing this survey please contact me at (234)600-0672 between 7 AM and 3 PM or through e-mail at [mscoville@cityofgirard.com](mailto:mscoville@cityofgirard.com).

A copy of our full backflow prevention program can be found at our website [www.cityofgirard.com](http://www.cityofgirard.com) under water tab.

Sincerely,

Michael T. Scoville

Date:

Backflow Coordinator

**City of Girard**  
**Water Distribution Department**  
**Backflow Division**  
**100 W. Main St.**  
**Girard, OH. 44420**

**SURVEY RESULTS: NO BACKFLOW PREVENTER NECESSARY**

Date:

RE: Cross-connection Control At:

(Premise Address)

Dear Sir or Madam:

The City of Girard Water Distribution Department Backflow Coordinator recently conducted a water use survey at the above premise as required by the State of Ohio Environmental Protection Agency Regulation Chapter 3745-95 and the City of Girard Ordinance Number 6191-90.

The purpose of the survey was threefold:

1. To determine the kind of facility at the above premise.
2. To determine if actual or potential cross-connections exist.
3. To determine the requirements for approved cross-connection control.

Based on the attached survey it has been determined that no apparent hazards to the public water supply exist. Therefore, no backflow requirements are necessary.

If I can be of further assistance, please contact me at (234)600-0672 between 7 AM and 3 PM or through e-mail at [mscoville@cityofgirard.com](mailto:mscoville@cityofgirard.com).

A copy of our full backflow prevention program can be found at our website [www.cityofgirard.com](http://www.cityofgirard.com) under water tab.

Sincerely,

Michael T. Scoville

Date:

Backflow Coordinator

**City of Girard**  
**Water Distribution Department**  
**Backflow Division**  
**100 W. Main St.**  
**Girard, OH. 44420**

**SURVEY RESULTS: BACKFLOW PREVENTER REQUIRED**

Date:

RE: Cross-connection Control At:

(Premise Address)

Dear Sir or Madam:

The City of Girard Water Distribution Department Backflow Coordinator recently conducted a water use survey at the above premise as required by the State of Ohio Environmental Protection Agency Regulation Chapter 3745-95 and the City of Girard Ordinance Number 6191-90.

A backflow preventer must be purchased, installed and maintained by the owner at a location specified by the City of Girard Backflow Prevention Program.

The device must be of the size, make and model that has been approved by the City of Girard Water Distribution Department Backflow Coordinator. A listing of approved backflow preventers is enclosed.

A person certified as competent to test backflow prevention devices by the City of Girard Water Distribution Department Backflow Coordinator must test a backflow prevention device every 12 months.

If termination of the water supply for a period of one-half hour for the purposes of testing will cause a serious hardship, a manifold setting of backflow preventers is strongly recommended.

Ohio Plumbing Code requires that a means of preventing thermal expansion must be installed if a backflow preventer is required. Your plumber should be familiar with this requirement.

Based on the attached survey and in order to comply with city and state laws, the following requirements must be initiated within ninety days from the date of this letter.

- 1.
- 2.

If I can be of further assistance, please contact me at (234)600-0672 between 7 AM and 3 PM or through e-mail at [mscoville@cityofgirard.com](mailto:mscoville@cityofgirard.com).



A copy of our full backflow prevention program can be found at our website [www.cityofgirard.com](http://www.cityofgirard.com) under water tab.

Sincerely,

Michael T. Scoville

Date:

Backflow Coordinator

**City of Girard  
Water Distribution Department  
Backflow Division  
100 W. Main St.  
Girard, OH. 44420**

**OWNER'S NO INSTALLATION**

Date:

RE: Cross-connection Control At:

(Premise Address)

Dear Sir or Madam:

Re-inspection of the above premise disclosed that the required backflow preventer has not been installed. This inspection was made on (Date).

In accordance with the City of Girard Ordinance Number 6191-90 and the Ohio Environmental Protection Agency Regulation Chapter 3745-95, the failure to install the required backflow preventer shall result in discontinuance of your water service.

This letter is notice that the required backflow preventer must be installed within thirty days.

If you have any questions please contact me at (234)600-0672 between 7 AM and 3 PM or through e-mail at [mscoville@cityofgirard.com](mailto:mscoville@cityofgirard.com).

A copy of our full backflow prevention program can be found at our website [www.cityofgirard.com](http://www.cityofgirard.com) under water tab.

Sincerely,

Michael T. Scoville

Date:

Backflow Coordinator

**City of Girard  
Water Distribution Department  
Backflow Division  
100 W. Main St.  
Girard, OH. 44420**

**CERTIFIED MAIL**

**OWNER'S NO INSTALLATION**

Date:

RE: Cross-connection Control At:

(Premise Address)

Dear Sir or Madam:

On (Date) you were notified that the premise at the above location failed to meet the requirements of the State of Ohio Environmental Protection Agency Regulation Chapter 3745-95 and the City of Girard Ordinance Number 6191-90 as they pertain to cross-connection control.

It is necessary that an approved (Type) backflow preventer be installed on the city water service line according to City of Girard Backflow Program specifications immediately.

This letter is your notification that unless the requirements are observed or positive steps taken to comply with these requirements and the City of Girard Backflow Coordinator is properly informed, the water supply to the above address will be terminated without further notice on or about (Date).

If you have any questions regarding this violation or would like to discuss the situation further, feel free to please contact me at (234)600-0672 between 7 AM and 3 PM or through e-mail at [mscoville@cityofgirard.com](mailto:mscoville@cityofgirard.com).

A copy of our full backflow prevention program can be found at our website [www.cityofgirard.com](http://www.cityofgirard.com) under water tab.

Sincerely,

Michael T. Scoville

Date:

Backflow Coordinator

**City of Girard**  
**Water Distribution Department**  
**Backflow Division**  
**100 W. Main St.**  
**Girard, OH. 44420**

**BACKFLOW PREVENTER TEST NOTIFICATION**

Date:

Dear Customer:

Backflow prevention is a requirement of the State of Ohio Department of Commerce, the Ohio Environmental Protection Agency, and the Water Works. The purpose of the backflow preventer installed at the water meter is to prevent any contamination from flowing back into the public water system. The device is to be tested no less than once every 12 months, by a tester approved by the Water Works, to ensure that it is operating properly.

I've included a listing of the names and numbers of those persons that are currently certified by the Water Works as competent testers. The list is as complete as is available and is provided only to aid you. Please contact the certified backflow tester of your choice.

You must return the original test sheet to my office via mail or email, my email **No faxes will be accepted.**

Three important items must be met in the testing of your device:

1. The backflow preventer test must be completed within 30 days of this letter and the results returned to the Water Works within 3 days. I've included an individual test sheet for each device that is due to be tested. This test sheet has all the information that identifies the premise, device location, size, type, and manufacturer number. Only the completed original test sheet will be accepted.
2. If a device fails to pass the annual test, we must be notified and the device must be repaired immediately. Please call Mike Scoville at (234) 600-0672 with the information that the device has failed. If you need an extension on time, an additional 7 days may be granted.
3. Failure to provide a passing test result within the 30-day period or to make contact with the Mike Scoville at (234) 600-0672 will result in the termination of your water service. Your water service will be turned back on only to test the device and will remain on only if the device passes the test. Obviously, the reason your water service would be interrupted is to ensure the protection of the public water supply.

If you have any questions, please contact me at me at (234)600-0672 between 7 AM and 3 PM or through e-mail at [mscoville@cityofgirard.com](mailto:mscoville@cityofgirard.com).

A copy of our full backflow prevention program can be found at our website [www.cityofgirard.com](http://www.cityofgirard.com) under water tab.

Sincerely,

Michael T. Scoville

Date:

Backflow Coordinator

**City of Girard**  
**Water Distribution Department**  
**Backflow Division**  
**100 W. Main St.**  
**Girard, OH. 44420**

**BACKFLOW PREVENTER TEST: OVERDUE NOTICE**

Date

Dear Customer:

Protection of the public water supply is of the utmost concern to the Water Works, and we feel that it should be a high priority with you also. You have a backflow preventer installed at your water meter, which is a vital link in this protection. Recently we requested your cooperation in having your backflow preventer tested. This is required by the Ohio Environmental Protection Agency and City of Girard Water Distribution Department Backflow Division.

It is the property owners' responsibility to have the backflow preventer tested and the test results mailed to the City of Girard Water Distribution Department Backflow Division. As of this date, we have not received the test results. Perhaps this is just an oversight in forgetting to mail the results to us. If the results have been mailed, please disregard this letter.

If a device fails to pass the annual test, we must be notified and the device repaired immediately. If circumstances warrant, an extension of time may be granted.

Failure to provide a passing test result or failure to contact the Mike Scoville at (234) 600-0672 about a failing test can result in the interruption of your water service. With this in mind, we request that you provide the required test information to us no later than one week from the date of this letter.

If you have any questions, please contact me at me at (234)600-0672 between 7 AM and 3 PM or through e-mail at [mscoville@cityofgirard.com](mailto:mscoville@cityofgirard.com).

A copy of our full backflow prevention program can be found at our website [www.cityofgirard.com](http://www.cityofgirard.com) under water tab.

Sincerely,

Michael T. Scoville

Date:

Backflow Coordinator

**City of Girard**  
**Water Distribution Department**  
**Backflow Division**  
**100 W. Main St.**  
**Girard, OH. 44420**

**BACKFLOW PREVENTER APPROVED CERTIFIED TESTERS LETTER**

Date

Dear Certified Tester:

My name is Michael Scoville. I am currently in charge of the City of Girard's Backflow Prevention Program. I have created the backflow program based off of EPA, OTCO, ODOC, and ORC rules and regulations. I was required by the Ohio Environmental Protection Agency to create this program for the City of Girard. I have enclosed a copy of the Backflow Program Acknowledgement and Guidelines for Certified Testers. All requirements must be met and will be enforced.

The City of Girard has created this backflow program for the protection of its public water supply and its consumers. This program shall be followed by all public water supply users, certified backflow prevention testers, certified plumbers and the City of Girard water department for the testing, installation and inspection of all backflow prevention devices installed within the City of Girard's water supply system.

All newly installed Backflow Preventers must be inspected and approved by the City of Girard Backflow Prevention Coordinator.

All certified testers shall submit all renewals of their credentials to test when they expire as well as submit their annual certification letter of the calibration of the testing equipment used. All testing equipment shall be calibrated yearly and all documentation sent to the City of Girard upon receipt of the said certification letter.

All certified testers shall use only approved testing sheets which will be sent to the customer's location along with an annual letter that is sent to the consumer/owner of the backflow prevention device. Each location tested shall have a tag which will be supplied by the City of Girard attached to the devices tested and all information must be filled out during testing, unless said tester already has tags, if more tags are needed please contact the City of Girard Water Department.

Any certified tester that fails to notify the City of Girard of any consumers backflow prevention device failures, or has not sent a copy of their renewals or calibration certificates will be removed from the approved certified testers list which will be posted on the City of Girard's website until all said documentation is provided, non-reported failures will cause permanent removal from approved list.

All test documents shall be sent via email or through the mail. No more faxes will be accepted. All test documents must be legible, if they are not, a request for a legible copy will be sent to the tester.

Only fire and containment testing documents will be accepted by the City of Girard. The City of Girard is not responsible for any isolation device records and will not accept any isolation test documents.

If you have any questions, please contact me at me at (234)600-0672 between 7 AM and 3 PM or through e-mail at [mscoville@cityofgirard.com](mailto:mscoville@cityofgirard.com).

A copy of our full backflow prevention program can be found at our website [www.cityofgirard.com](http://www.cityofgirard.com) under water tab.

Sincerely,

Michael T. Scoville

Date:

Backflow Coordinator



# APPENDIX A



Alternative to the Installation of an Approved  
Backflow Preventer on Service Connections  
Where There is an Auxiliary Water System

Division: DDAGW  
Number: PWS-02-003  
Category: Public Water System-Guidance  
Status: Final  
Issued: Oct. 15, 2015

## **I. PURPOSE**

Under paragraph (C)(2) of Ohio Administrative Code (OAC) rule 3745-95-04 public water systems are not required to install an approved backflow preventer on service connections where there is an auxiliary water system on the real property that is owned or under control of the consumer and adjacent to the premises, provided the system satisfies the conditions of paragraphs (C)(2)(a) through (C)(2)(e). This document is intended to provide guidance and implementation materials to assist public water systems in achieving compliance with this alternative requirement. It is intended that utilization of these procedures and materials will result in compliance with the requirements of OAC rule 3745-95-04(C)(2); *however, they are provided only as guidance and are not intended to limit a public water system from utilizing other means to achieving compliance.*

## **II. BACKGROUND**

OAC rule 3745-95-04 became effective May 1, 2003. It provides an alternative to the requirement to install an approved backflow preventer on service connections to premises that have an auxiliary water system on the real property adjacent to the premises that is owned or under control of the consumer but not part of the premises. The provider of water may choose the alternative requirement at their discretion. However, for the alternative to be permitted the supplier of water must address each of the following items: (a) determine, on a case-by-case basis, that a backflow preventer is not required, taking into consideration conditions that exist on the premises and adjacent real property; (b) require the consumer to sign a cross-connection control agreement that specifies penalties for creating a connection between the public water system and the auxiliary water system; (c) conduct inspections at least every twelve months to ensure there is no connection or means of connection has been created; (d) maintain an inventory of consumers with auxiliary water systems; and (e) develop and implement an education program

to inform all consumers served by the public water system of the dangers of cross-connections and how to eliminate them.

**Applicable definitions:**

*“Auxiliary water system” means any water system on or available to the premises other than the public water system. These auxiliary water systems shall include used water or water from a source other than the public water system, such as wells, cisterns or open reservoirs that are equipped with pumps or other prime movers, including gravity.*

*“Premises” means any building, structure, dwelling or area containing plumbing or piping supplied from a public water system.*

*“Real property” as used in OAC rule 3745-95-04(C) is intended to mean the land surrounding or adjacent to, the premises and is owned or controlled by the consumer of water.*

**III. GUIDANCE**

**1. OAC rule 3745-95-04(C), effective May 1, 2003, states the following:**

“(C) The following requirements apply to premises that have an auxiliary water system on the real property that is owned or under control of the consumer and adjacent to the premises.

- (1) A physical separation shall be maintained between the public water system or a consumer's water system and the auxiliary water system as required by paragraph (B) of rule 3745-95-02 of the Administrative Code; and
- (2) An approved backflow prevention device shall be installed on each service connection serving the consumer's water system, unless the supplier of water does all of the following:
  - (a) Determines, on a case-by-case basis, that the installation of an approved backflow prevention device on a service connection is not required in consideration of factors including, but not limited to, the past history of cross connections being established or re-established on the

premises, the ease or difficulty of connecting the auxiliary water system with the public water system on the premises, the presence or absence of contaminants on the property or other risk factors;

- (b) Requires the consumer to sign an agreement which specifies the penalties, including those set forth in rule 3745-95-08 of the Administrative Code, for creating a connection between the public water system and the auxiliary water system;
- (c) Conducts or causes to be conducted an inspection at least every twelve months to certify that no connection or means of connection has been created between the public water system and the auxiliary water system;
- (d) Maintains an inventory of each consumer's premises where an auxiliary water system is on or available to the premises, or on the real property adjacent to the premises; and
- (e) Develops and implements an education program to inform all consumers served by the public water system about the dangers of cross-connections and how to eliminate cross connections.”

## **2. Additional guidance documents**

To facilitate compliance with OAC rule 3745-95-04(C)(2), four documents have been developed. These documents collectively address all components identified in OAC rule 3745-95-04(C)(2) and are contained as appendixes to this guidance. The supplier of water is encouraged to utilize these materials or equivalent materials in order to develop and implement an acceptable program. Each of the four documents is described below.

### 1. Annual Survey for Auxiliary Water Systems

This survey form provides a means for evaluating the conditions that exist on the premises and the real property. It is intended to assist in achieving compliance with OAC rule 3745-95-04(C)(2)(a), (c) and (d). This survey form is intended for use by an employee or other person acceptable to the supplier of water when surveying properties with auxiliary water systems.

The survey form may be used for both the initial and annual surveys. Public water systems may modify this survey form or develop their own survey to suit their needs as long as all of the information required by OAC rule 3745-95-04(C)(2)(a) is included.

If a backflow preventer is deemed necessary on the service connection, the type of backflow preventer required must be determined by the supplier of water based on the degree of hazard. The consumer has the option of permanently eliminating the auxiliary water system or other potential backflow hazard in lieu of installing a backflow preventer and should be encouraged to do so as the option most protective of public health. The survey should be signed and dated by the person conducting the survey.

In accordance with OAC rule 3745-95-06, annual surveys must be maintained by the supplier of water for at least five years. It is recommended that surveys be maintained by the supplier of water for as long as the backflow prevention method is in effect. This is intended to provide a history of the establishment of cross-connections or other backflow hazards.

## 2. Recommended Agreement Language

This document was developed to assist the public water system in meeting the requirements of OAC rule 3745-95-04(C)(2)(b). It provides recommended language for the supplier of water to include for a suitable agreement and includes the penalties, as set forth in OAC rule 3745-95-08, for creating a connection between the public water system and the auxiliary water system. Definitions of specific terms should also be included as well as references to any applicable ordinances, policies, rules, regulations or user agreements established by the supplier of water.

## 3. Backflow Education Program Minimum Requirements

The Cross-Connection Education Program, Recommended Learning Objectives document is intended to provide the supplier of water a framework for developing educational materials for implementing an educational program as required by OAC rule 3745-9504(C)(2)(e).

The supplier of water is required to develop and implement a backflow education program to educate all consumers on the dangers of cross-

connections and how to eliminate cross connections when the alternative to the installation of an approved backflow preventer is offered. If the supplier of water does not offer this option, a backflow education program is not required, although it is strongly encouraged as a component of all backflow prevention programs.

The method of delivery is not specified by rule but may include: mail, posting on the internet, public meetings, hand delivery, publication in newspaper(s), and inclusion in the consumer confidence report or public service announcements. Educational materials may include brochures, fact sheets, audio and video recordings, posters and presentations.

#### 4. Educational Brochure

“Backflow Prevention and Cross-Connection Control, Protecting Our Public Water System” is a brochure the Division of Drinking and Ground Waters (DDAGW) developed as an educational tool for water systems to assist in achieving compliance with the educational program required by OAC rule 3745-95-04(C)(2)(e). The brochure covers the information DDAGW believes customers need to know about backflow prevention and complying with Ohio backflow prevention rules. The brochure is available both in “pdf” and “Microsoft Word” formats on the division’s website. Public water systems are not required to utilize this brochure and may utilize material from other sources or develop their own educational materials.

All program material used by a PWS must be available for review by Ohio EPA Division of Drinking and Ground Waters.

## **IV. ATTACHMENTS**

- A. Instructions for Completing Annual Survey for Auxiliary Water Systems.
- B. Annual Survey for Auxiliary Water Systems.
- C. Cross-Connection Education Program Requirements and Recommended Learning Objectives.
- D. Recommended Agreement Language.
- E. Backflow Prevention and Cross Connection Control, Protecting Our Public Water System.

## **V. HISTORY**

The Division of Drinking and Ground Waters first issued this guidance on March 16, 2004 and revised on June 11, 2004. The guidance was amended to include new rule language in the guidance and the educational brochure, and was reissued on October 15, 2015.

# **APPENDIX B**

## **STATE OF OHIO LAWS AND RULES PERTAINING TO BACKFLOW PREVENTION AND CROSS-CONNECTION CONTROL**

Ohio state laws and Ohio state rules pertaining to backflow prevention and cross-connection control are contained in the Revised Code and in rules of the Ohio Environmental Protection Agency and Ohio Department of Commerce - Division of Industrial Compliance and the Ohio Building Code. Those statutes and rules which appear to be directly concerned with backflow prevention are listed below. For an up to-date listing and for the text of the regulations, see LAW Writer® Ohio Laws and Rules website at <http://codes.ohio.gov/>.

[Chapter 4101:3-6 (the Ohio Plumbing Code) of the Ohio Administrative Code, entitled Plumbing, is part of the Ohio Basic Building Code and contains rules on water supply and distribution that are directly concerned with backflow prevention and cross-connection control. Rules are provided for informational purposes only. See Ohio Department of Commerce, Industrial Compliance, Plumbing website for the most up-to date and complete listing of these rules at <http://www.com.ohio.gov/dico/> Another web link resource is from the International Code Council Online Library, under electronic products tab, free resources heading, then free codes, state of Ohio code, at: <http://publicecodes.cyberregs.com/st/oh/st/OH-P-2011-000004.htm>]

[Chapter 3745-95 (Ohio EPA, Backflow Prevention and Cross-Connection Control) of the Ohio Administrative Code became effective on July 1, 1972. The rules undergo a review every five years. These rules are provided for informational purposes only. See Ohio EPA's Division of Drinking and Ground Waters website for an up-to-date and complete listing of the rules by clicking on the tab, "Effective Rules" at <http://epa.ohio.gov/ddagw/rules.aspx>.

### **Ohio Board of Building Standards**

Ohio Revised Code

- Section 3781.03 – Enforcement of building standards
- 3781.06 – Jurisdiction of the building standards; definitions
- 3781.10 – Duties of the Board of Building Standards
- 3781.11 – Rules and regulations of the Board of Building Standards
- 3791.01 – General prohibitions

- 3791.02 – Prohibition: owner’s failure to obey orders; penalty
- 3791.03 – Prohibitions: others; penalty
- 3791.04 – Submission of plans; approvals

Ohio Administrative Code

Division 4101:3 Ohio Plumbing Code

4101:7 Certification Rules

Rule 4101:8-25-01 Residential Code of Ohio, “Plumbing Systems” chapter

**Ohio Division of Industrial Compliance**

Ohio Revised Code

Section 3703.01 – Division of Industrial Compliance powers and duties

3703.03 – Division to enforce rules governing plumbing and plan approval

3703.05 – Right of entry for plumbing inspectors

3703.06 – Plumbing certificates: issuance, posting, revocation

3703.07 – Plumbing permit required; fee

3703.08 – Duty of the owner to comply with notices

3703.10 – Prosecutions and proceedings for violations

3703.21 – Backflow advisory board; Certification of backflow technicians; civil penalty

3703.99 – Penalties

**Ohio Administrative Code**

Rule 1301:3-2-02 – Definitions

1301:3-2-03 – Examination for Plumbing Inspector Certification

1301:3-2-04 – Jurisdiction of Plumbing Inspector

1301:3-2-05 – Certificate required for Plumbing inspector

1301:3-2-06 – Certificate Renewal

1301:3-2-07 – Fees for Plumbing inspectors

1301:3-2-08 – Denial, revocation or suspension of a Plumbing inspectors Certificate

1301:3-2-09 – Appeals for Plumbing inspector certificates

Rule 1301:3-7-01 – Definitions

1301:3-7-02 – Certification as a Backflow Technician

1301:3-7-03 – Backflow Technician Examination

1301:3.7.04 – Fees for backflow application and examination



- 1301:3.7.05 – Renewal of Certificate as a Backflow Technician
- 1301:3.7.06 – Training agency for backflow technician education
- 1301:3.7.07 – Denial, revocation or suspension of a backflow certificate
- 1301:3.7.08 – Appeal for backflow technician

## **Ohio Environmental Protection Agency**

### Ohio Revised Code

- Section 6109.04 – Control of public water systems
  - 6109.07 – Plan submittal and approval
  - 6109.13 – Auxiliary water systems
  - 6109.14 – Notice of the danger of contamination
  - 6109.15 – Orders to make improvements, corrections and changes
  - 6109.31 – Violations
  - 6109.32 – Enforcement actions
  - 6109.33 – Penalties
  - 6109.34 – Access for inspections and investigations

### Ohio Administrative Code

- Rule 3745-95-01 – Backflow prevention and cross-connection control definitions
- 3745-95-02 – Cross-connections
- 3745-95-03 – Surveys and investigations
- 3745-95-04 – Where protection is required
- 3745-95-05 – Type of protection required
- 3745-95-06 – Backflow prevention devices
- 3745-95-07 – Booster pumps
- 3745-95-08 – Violations
- 3745-95-09 – Requirement for yard hydrants

Chapter 3745-91 – Plan Approval (Rules 3745-91-01 through 3745-91-09)

## **Ohio Department of Health**

### Ohio Revised Code

- Chapter 3729. – Recreational vehicle parks, recreation camps, combined and temporary park-camps

## Ohio Administrative Code

### Chapter 3701-25 – Camps

### Chapter 3701-26 – Recreational vehicle park, combined park-camps and temporary park-camps (i.e., rule on park or camp water supply; backflow prevention on water supply)

The following portions of the Ohio Revised Code concern the powers and duties of political subdivisions and private companies in Ohio regarding the establishment, operation, maintenance and protection of public water systems and the regulation of plumbing systems within buildings.

### **County Systems**

#### Section 307.15 – Board of county commissioners; contracts with other units of Government

307.37 – Construction in unincorporated areas

307.38 – County building inspector; duties; hearings

307.381 – County board of appeals may be established

307.40 – Unlawful construction may be enjoined

#### Chapter 6103. – County water supply systems; definitions

#### Section 6115.04 – Sanitary districts: organization and purposes

6115.18 – Sanitary districts: powers of the board of directors

6115.19 – Sanitary districts: organized to provide a water supply

6115.23 – Sanitary districts: board of directors may make and enforce Regulations; noncompliance

### **Municipal Corporations**

#### Section 715.01 – General powers

715.08 – Water supply

715.26 – Building regulation: erection; inspection; removal; repair

715.29 – Sanitation

717.01 – Specific powers: acquisition of public works

731.17 – Procedures for legislation

735.02 – Director of Public Service: duties

735.03 – Board of Public Utilities

735.27 – Villages: care of public institutions

735.273 – Village Administrator: powers and duties

- 735.29 – Board of Public Affairs: powers and duties
- 743.02 – Utilities: bylaws and regulations
- 743.12 through
- 743.16 – Extension of water service outside the corporation limits; supervision; protection
- 743.17 – Water works in a contiguous municipal corporation; protection
- 743.24 – Contract for a water supply; protection

### **PUCO Regulated Utility Companies**

Chapter 4933. – PUCO regulated utility companies

### **Conservancy Districts**

- Section 6101.04 – Conservancy districts: organizations and purposes
- 6101.13 – Official plan; execution
- 6101.15 – Powers of the board of directors
- 6101.19 – Board of directors may make and enforce rules and regulations

### **Regional Water and Sewer Districts**

- Section 6119.01 – Organization; purpose
- 6119.06 – Rights, powers and duties
- 6119.07 – Powers vested in a board of trustees
- 6119.08 – Rules and regulations
- 6119.35 – Approval or rejection of plans by the Ohio Environmental Protection Agency

# APPENDIX C

## **ORC Section 3745-95 - Backflow Prevention and Cross-Connection Control**

Current through All Regulations Passed and Filed through January 24, 2020

### **ORC Section 3745-95-01 - Backflow prevention and cross-connection control definitions**

As used in this chapter of the Administrative Code:

**(A) (1)** "Air gap separation" means the unobstructed vertical distance through the free atmosphere between the lowest opening from any pipe or faucet supplying water to a tank, plumbing fixture, or other device and the flood level rim of the receptacle.

**(2)** "Approved" means that a backflow prevention assembly, device, or method has been accepted by the supplier of water and the director as suitable for the proposed use.

**(3)** "Auxiliary water system" means any water system on or available to the premises other than the public water system. These auxiliary water systems shall include used water or water from a source other than the public water system, such as wells, cisterns or open reservoirs that are equipped with pumps or other prime movers, including gravity.

**(B) (1)** "Backflow" means the flow of water or other liquids, mixtures, or substances into the distributing pipes of a potable water supply from any source other than the intended source of the potable water supply.

**(2)** "Backflow preventer" means any assembly, device, method or type of construction intended to prevent backflow into a potable water system. This definition applies wherever "backflow prevention device" is used in this chapter.

**(3)** "Booster pump" means any device which is intended to increase the in-line water pressure.

**(C) (1)** "Consumer" means the owner or person in control of any premises supplied by or in any manner connected to a public water system.

**(2)** "Consumer's water system" means any water system, located on the consumer's premises, supplied by or in any manner connected to a public water system. A household plumbing system is considered to be a consumer's water system.

**(3)** "Containment principle backflow preventer" is a backflow preventer, installed in a consumer's water system, that is intended to contain the water within the premises in order to prevent any polluted or contaminated water from backflowing into the public water system. Typically, the containment principle backflow preventer is placed at the service connection unless placement is otherwise specified by rule herein.

**(4)** "Cross-connection" means any arrangement whereby backflow can occur.

**(D) (1)** "Degree of hazard" is a term derived from an evaluation of the potential risk to health and welfare.

**(2)** "Director" means the director of environmental protection or the director's duly authorized representative.

**(3)** "Double check valve assembly" means an assembly composed of two single, independently acting, check valves including tightly closing shutoff valves located at each end of the assembly and suitable connections for testing the water tightness of each check valve.

**(4)** "Double check-detector check valve assembly" means a specially designed assembly composed of a line-size approved double check valve assembly with a specific bypass water meter and a meter-sized approved double check valve assembly. The meter shall register accurately for only very low rates of flow and shall show a registration for all rates of flow.

**(E)** [Reserved.]

**(F)** [Reserved.]

**(G)** [Reserved.]

**(H) (1)** "Health hazard" means any condition, device, or practice in a water system or its operation that creates, or may create, a danger to the health of users.

**(2)** "Human consumption" means the ingestion or absorption of water or water vapor as the result of drinking, cooking, dishwashing, hand washing, bathing, showering or oral hygiene.

**(I)** "Interchangeable connection" means an arrangement or device that will allow alternate but not simultaneous use of two sources of water and includes an approved reduced pressure principle backflow prevention assembly or an approved reduced pressure principle-detector assembly on the public water system side of the connection.

**(J)** [Reserved.]

**(K)** [Reserved.]

**(L)** [Reserved.]

**(M)** [Reserved.]

**(N)** [Reserved.]

**(O)** [Reserved.]

**(P) (1)** "Person" means the state, any political subdivision, public or private corporation, individual, partnership, or other legal entity.

**(2)** "Pollutional hazard" means a condition through which an aesthetically objectionable or degrading material, which is not dangerous to the public water system or health of users, may enter the public water system or portion of a consumer's water system.

**(3)** "Potable water" means water intended for human consumption.

**(4)** "Premises" means any building, structure, dwelling or area containing plumbing or piping supplied from a public water system.

**(5)** "Pressure vacuum breaker" means an assembly composed of an independently acting spring loaded check valve located downstream of an independently acting spring loaded air inlet valve including, tightly closing shutoff valves located at

each end of the assembly and suitable connections for testing the integrity of the air inlet and check valves.

**(6)** "Process fluids" means any fluid or solution which may be chemically, biologically or otherwise contaminated or polluted in a form or concentration such as would constitute a pollutional, system, health or severe health hazard if introduced into the public water system or portion of a consumer's water system. This includes, but is not limited to the following: **(a)** Polluted or contaminated waters.

**(b)** Process waters.

**(c)** Used waters originating from a public water system which may have deteriorated in sanitary quality.

**(d)** Cooling waters.

**(e)** Contaminated natural waters taken from wells, lakes, streams or irrigation systems.

**(f)** Chemicals in solution or suspension.

**(g)** Oils, gases, acids, alkalis, and other liquid and gaseous fluids used in industrial or other processes, or for fire fighting purposes.

**(7)** "Public water system" has the same meaning as in rule 3745-81-01 of the Administrative Code.

**(Q)** [Reserved.]

**(R) (1)** "Reduced pressure principle backflow prevention assembly" means an assembly containing a minimum of two independently acting check valves together with an automatically operated pressure differential relief valve located between the two check valves. During normal flow and at the cessation of normal flow, the pressure between these two checks shall be less than the supply pressure. In case of leakage of either check valve, the differential relief valve, by discharging to the atmosphere, shall operate to maintain the pressure between the check valves at less than the supply pressure. The unit must include tightly closing shutoff valves located at each end of the assembly, and each assembly shall be fitted with properly located test cocks.

**(2)** "Reduced pressure principle-detector assembly" means a specially designed assembly composed of a line-size approved reduced pressure principle backflow prevention assembly with a specific bypass water meter and a meter sized approved reduced pressure principle backflow prevention assembly. The meter shall register accurately for only very low rates of flow and shall show a registration for all rates of flows.

**(S) (1)** "Service connection," for the purposes of this chapter, means the terminal end of a service line from the public water system. If a meter is installed at the end of the service, then the service connection means the downstream end of the meter.

**(2)** "Severe health hazard" means a health hazard to users that could reasonably be expected to result in significant morbidity or death.

**(3)** "Supplier of water" means the owner or operator of a public water system.

**(4)** "System hazard" means a condition posing an actual or potential threat of damage to the physical properties of the public water system or a consumer's water system.

**(T)** [Reserved.]

**(U)** "Used water" means any water supplied by a supplier of water from a public water system to a consumer's water system after the water has passed through the service connection and is no longer under the control of the supplier.

**(V)** [Reserved.]

**(W) (1)** "Water system" means a system for the provision of piped water or process fluids, and includes any collection, treatment, storage or distribution facilities used primarily in connection with such system.

**(2)** "Weep holes" means a series of small diameter holes located in the wall of the supply pipe for a yard hydrant that allow for drainage of accumulated water from the delivery piping. These holes are usually part of a plunger and valve system that seals off the holes during water usage and opens the holes during shutdown. These openings are located below ground level and below the frost line in areas where the threat of freezing exists.



(X) [Reserved.]

(Y) "Yard hydrant" means a device that is located outside of a building, equipped with a valved mechanism that controls the delivery of potable water, and is not designed to supply a fire department pumper. (Z) [Reserved.]

Ohio Admin. Code 3745-95-01

Effective: 10/26/2015 Five Year Review (FYR) Dates: 07/06/2015 and 10/26/2020  
Promulgated Under: 119.03 Statutory Authority: 6109.04 Rule Amplifies: 6109.04,  
6109.13 Prior Effective Dates: 07/01/72, 11/26/80, 05/01/03, 10/01/06, 04/19/12

**Section 3745-95-02 - Backflow prevention and cross-connection control.**

(A) No person shall install or maintain a water service connection to any premises where actual or potential cross-connections to a public water system or a consumer's water system may exist unless such actual or potential cross-connections are abated or controlled to the satisfaction of the supplier of water.

(B) No person shall install or maintain a connection between a public water system or consumer's water system and an auxiliary water system unless the auxiliary water system, the method of connection and the use of such system have been approved by the supplier of water and by the director as required by section 6109.13 of the Revised Code.

(C) A public water system shall develop and implement a backflow prevention and cross-connection control program consistent with this chapter.

Ohio Admin. Code 3745-95-02

Effective: 10/26/2015 Five Year Review (FYR) Dates: 07/06/2015 and 10/26/2020  
Promulgated Under: 119.03 Statutory Authority: 6109.04 Rule Amplifies: 6109.04,  
6109.13 Prior Effective Dates: 07/01/72, 11/26/80, 05/01/03

**Section 3745-95-03 - Surveys and investigations.**

(A) The supplier of water shall conduct or cause to be conducted an initial assessment and periodic surveys or investigations of water use practices within a consumer's premises to determine whether there are actual or potential cross-connections to the consumer's water system through which contaminants or pollutants could backflow into the public water system or determine where in the

judgment of the supplier of water, a pollutional system, health or severe health hazard to the public water system exists.

To meet this requirement, the supplier of water shall conduct or cause to be conducted an on-site investigation of all premises at least every five years to identify changes in water use practices at the consumer's property so that new or increased hazards to the water supply are identified and mitigated.

**(1)** In lieu of conducting an on-site investigation of all premises every five years, the supplier of water can document, in writing, an alternate, on-going, methodology to identify changes in water use practices that may represent a new or increased hazard to the public water supply. An on-site investigation is required when a potential new or increased hazard is suspected to confirm the degree of risk and how it will be addressed. Information obtained through a water use survey questionnaire or in coordination with the local building, zoning, health, fire protection and other licensing agencies may be used as an indicator of when an on-site investigation should be conducted. Other triggers, such as a request to the supplier of water for a new or additional service line, or an additional or larger meter should warrant an on-site investigation.

**(2)** In lieu of conducting an on-site investigation of each residential premise, the supplier of water may institute an on-going educational campaign to inform consumers of common backflow hazards created during residential water use and provide a reporting mechanism for suspected cross-connections. An education campaign may use local media and advertising resources, but must also include information delivered, either electronically or hard copy, to each residential service connection at least annually.

**(B)** The supplier of water, or the supplier's authorized representative, shall have the right to enter premises served by the public water system at all reasonable times for the purpose of making surveys and investigations of water use practices within the premises.

**(C)** On request by the supplier of water, or the supplier's authorized representative, the consumer shall furnish the supplier, or the supplier's authorized representative, information on water use practices within the consumer's premises.

**(D)** Paragraph (A) of this rule does not relieve the consumer of the responsibility for conducting, or causing to be conducted, periodic surveys of water use practices on his premises to determine whether there are actual or potential cross-

connections in the consumer's water system through which contaminants or pollutants could backflow into a public water system or a potable consumer's water system.

Ohio Admin. Code 3745-95-03

Effective: 10/26/2015 Five Year Review (FYR) Dates: 07/06/2015 and 10/26/2020  
Promulgated Under: 119.03 Statutory Authority: 6109.04 Rule Amplifies: 6109.04,  
6109.13 Prior Effective Dates: 07/01/72, 11/26/80

**Section 3745-95-04 - Where protection is required.**

(A) An approved backflow preventer shall be installed on each service line to a consumer's water system serving premises, where in the judgment of the supplier of water or the director, a pollutional, system, health or severe health hazard to the public water system exists.

(B) An approved backflow preventer shall be installed on each service line to a consumer's water system serving premises where any of the following conditions exist:

(1) Premises having an auxiliary water system on the premises, unless such auxiliary system is accepted as an additional source by the supplier of water and the source is approved by the director.

(2) Premises on which any substance is handled in such a fashion as to create an actual or potential hazard to a public water system. This shall include premises having sources or systems containing process fluids.

(3) Premises having internal cross-connections that, in the judgment of the supplier of water, are not correctable, or intricate plumbing arrangements which make it impracticable to determine whether or not cross-connections exist.

(4) Premises where, because of security requirements or other prohibitions or restrictions, it is impossible or impractical to make a complete cross-connection survey.

(5) Premises having a repeated history of cross-connections being established or re-established.

**(6)** Others specified by the director.

**(C)** The following requirements apply to premises that have an auxiliary water system on the real property that is owned or under control of the consumer and adjacent to the premises:

**(1)** A physical separation shall be maintained between the public water system or a consumer's water system and the auxiliary water system as required by paragraph **(B)** of rule 3745-95-02 of the Administrative Code.

**(2)** An approved backflow preventer shall be installed on each service connection serving the consumer's water system, unless the supplier of water does all of the following:

**(a)** Determines, on a case-by-case basis, that the installation of an approved backflow preventer on a service connection is not required in consideration of factors including, but not limited to, the past history of cross connections being established or re-established on the premises, the ease or difficulty of connecting the auxiliary water system with the public water system on the premises, the presence or absence of contaminants on the property or other risk factors.

**(b)** Requires the consumer to sign an agreement which specifies the penalties, including those set forth in rule 3745-95-08 of the Administrative Code, for creating a connection between the public water system and the auxiliary water system.

**(c)** Conducts or causes to be conducted an inspection at least every twelve months to certify that no connection or means of connection has been created between the public water system and the auxiliary water system.

**(d)** Maintains an inventory of each consumer's premises where an auxiliary water system is on or available to the premises, or on the real property adjacent to the premises.

**(e)** Develops and implements an education program to inform all consumers served by the public water system about the dangers of cross-connections and how to eliminate cross-connections.

**(D)** An approved backflow preventer shall be installed on each service line to a consumer's water system serving, but not necessarily limited to, the following

types of facilities unless the director determines that no severe health, health, system or pollutional hazard to the public water system exists:

- (1) Hospitals, mortuaries, clinics, nursing homes.
- (2) Laboratories.
- (3) Piers, docks, waterfront facilities.
- (4) Sewage treatment plants, sewage pumping stations, or storm water pumping stations.
- (5) Food or beverage processing plants.
- (6) Chemical plants.
- (7) Metal plating industries.
- (8) Petroleum processing or storage plants.
- (9) Radioactive material processing plants or nuclear reactors.
- (10) Car washes.
- (11) Others specified by the director.

**(E)** An approved backflow preventer shall be installed at any point of connection that is approved in accordance with paragraph (B) of rule 3745-95-02 of the Administrative Code between a public water system or a consumer's water system and an auxiliary water system, unless such auxiliary system is accepted as an additional source by the supplier of water and the source is approved by the director.

Ohio Admin. Code 3745-95-04

Effective: 8/15/2018 Five Year Review (FYR) Dates: 5/16/2018 and 08/15/2023  
Promulgated Under: 119.03 Statutory Authority: 6109.04 Rule Amplifies: 6109.04,  
6109.13, 6109.03, 6109.01 Prior Effective Dates: 07/01/1972, 11/26/1980,  
05/01/2003

### **Section 3745-95-05 - Type of protection required.**

(A) The type of protection required under paragraphs (A), (B), (C) and (D) of rule 3745-95-04 of the Administrative Code shall depend on the degree of hazard which exists as follows:

(1) An approved air gap separation shall be installed where a public water system may be contaminated with substances that could cause a severe health hazard.

(2) An approved air gap separation, an approved reduced pressure principle backflow prevention assembly or an approved reduced pressure detector check assembly shall be installed where a public water system may be contaminated with any substance that could cause a system or health hazard.

(3) An approved air gap separation, an approved reduced pressure principle backflow prevention assembly, an approved reduced pressure principle-detector check assembly, an approved double check valve assembly or an approved double check-detector check valve assembly shall be installed where a public water system may be contaminated with any substance that could cause a pollutional hazard.

(B) The type of protection required under paragraph (E) of rule 3745-95-04 of the Administrative Code shall be an approved air gap separation or an approved interchangeable connection. A removable spool piece connection is not an acceptable method.

(C) Where an auxiliary water system is used as a secondary source of water for a fire protection system, the provisions of paragraph (B) of this rule for an approved air gap separation or an approved interchangeable connection may be waived by the director, provided the following conditions exist:

(1) At premises where the auxiliary water system may be contaminated with substances that could cause a system, health or severe health hazard, a public water system or a consumer's water system shall be protected against backflow by installation of an approved reduced pressure principle backflow prevention assembly or an approved reduced pressure principle-detector check assembly.

(2) At all other premises, a public water system or a consumer's water system shall be protected against backflow by installation of an approved reduced pressure principle backflow prevention assembly, an approved reduced pressure principle-

detector check assembly, an approved double check valve assembly or an approved double check-detector check valve assembly.

(3) A public water system or a consumer's water system shall be the primary source of water for the fire protection system.

(4) The fire protection system shall be normally filled with water from a public water system or a consumer's water system.

(5) The water in the fire protection system shall be used for fire protection only, with no other use of water from the fire protection system downstream from the approved backflow prevention device.

(D) An exception to the requirement in paragraph (A)(2) of this rule may be applied when mitigating the health hazard associated with a water-only, residential-type irrigation system that is not subjected to backpressure and is not equipped with pumps or other prime movers which can create backpressure to the public or the consumer's water system. In this instance, an approved pressure vacuum breaker can be used to isolate the service line to the irrigation system in lieu of installing a containment assembly at the service connection. The same maintenance and testing requirements as outlined in rule for containment assemblies apply. This exception does not apply if an additive is used within the irrigation system. The supplier of water may determine other hazards exist that warrant additional containment protection at the service connection.

Ohio Admin. Code 3745-95-05

Effective: 10/26/2015 Five Year Review (FYR) Dates: 07/06/2015 and 10/26/2020  
Promulgated Under: 119.03 Statutory Authority: 6109.04 Rule Amplifies: 6109.04,  
6109.13 Prior Effective Dates: 07/01/72, 11/26/80, 05/01/03

### **Section 3745-95-06 - Backflow prevention devices.**

(A) Any containment principle backflow preventer required by rules 3745-95-04 and 3745-95-05 of the Administrative Code shall be of a model or construction approved by the supplier of water and conform to at least one of the following standards:

**(1)** For air gap separations: the specific edition of the American national standards institute (ANSI) and the American society of mechanical engineers (ASME) standard as referenced in rule 4101:3-13-01 of the Administrative Code.

**(2)** For reduced pressure principle backflow prevention assemblies: the specific edition of the ANSI and the American water works association (AWWA) standard, or the American society of sanitary engineering (ASSE) standard, or the Canadian standards association (CSA) standard as referenced in rule 4101:3-13-01 of the Administrative Code; or the foundation for cross-connection control and hydraulic research, university of Southern California specifications of backflow assemblies for reduced pressure principle assemblies - tenth edition (2009).

**(3)** For double check valve assemblies: the specific edition of the ANSI and the AWWA standard, or the ASSE standard, or the CSA standard as referenced in rule 4101:3-13-01 of the Administrative Code; or the foundation for cross-connection control and hydraulic research, university of Southern California specifications of backflow assemblies for double check valve assemblies - tenth edition (2009).

**(4)** For reduced pressure principle-detector assemblies: the specific edition of the ANSI and the ASSE standard, or the CSA standard as referenced in rule 4101:3-13-01 of the Administrative Code; or the foundation for cross-connection control and hydraulic research, university of Southern California specifications of backflow assemblies for reduced pressure principle-detector assemblies - tenth edition (2009).

**(5)** For double check-detector check valve assemblies: the ANSI and the ASSE standard, or the CSA standard as referenced in rule 4101:3-13-01 of the Administrative Code, or the foundation for cross-connection control and hydraulic research, university of Southern California specifications of backflow assemblies for double check-detector assemblies - tenth edition (2009).

**(6)** For pressure vacuum breakers: the ANSI and the ASSE standard, or the CSA standard as referenced in rule 4101:3-13-01 of the Administrative Code.

**(B)** Any containment principle backflow preventer required by rules 3745-95-04 and 3745-95-05 of the Administrative Code shall be installed at a location and in a manner approved by the supplier of water and shall be installed at the expense of the water consumer. In addition, any backflow prevention device required by paragraphs (B) and (C) of rule 3745-95-05 of the Administrative Code shall be



installed at a location and in a manner approved by the director as required by section 6109.13 of the Revised Code.

**(C)** It shall be the duty of the water consumer to maintain any containment principle backflow preventer required by rules 3745-95-04 and 3745-95-05 of the Administrative Code in proper working order and in continuous operation.

**(1)** The supplier of water shall retain authority over any containment principle backflow preventer required by rules 3745-95-04 and 3745-95-05 of the Administrative Code.

**(2)** It shall be the duty of the supplier of water to see that the tests and inspections required under this paragraph are made.

**(3)** The consumer shall, on any premises on which any containment principle backflow preventer required by rules 3745-95-04 and 3745-95-05 of the Administrative Code are installed, have thorough inspections and operational tests made of the backflow preventers at the time of installation or repair, and as may be reasonably required by the supplier of water or the director, but in all cases at least once every twelve months. These inspections and tests shall be at the expense of the water consumer and shall be performed by the supplier of water or a person approved by the supplier as qualified to inspect and test backflow preventers.

**(4)** These devices shall be repaired, overhauled or replaced at the expense of the consumer whenever they are found to be defective.

**(5)** Records of such inspections, tests, repairs and overhaul shall be kept by the consumer and made available to the supplier of water.

**(6)** The supplier of water shall maintain a paper or electronic record of inventory of survey, investigation and containment principle backflow preventer installation reports. Records of inspections, tests, repairs and overhauls related to the containment principle backflow preventer required by rules 3745-95-04 and 3745-95-05 of the Administrative Code shall be maintained by the supplier of water for a minimum of five years.

**(D)** The supplier of water shall inspect or cause to be inspected all installations where an approved connection exists between an auxiliary water system and the public water system or a consumer's water system at least once every twelve months and shall maintain an inventory of all such installations and inspection

records. Such inventories and inspection records shall be made available during sanitary surveys and at other reasonable times. Paper or electronic inspection records shall be maintained by the supplier of water for a minimum of five years.

(E) Containment principle backflow preventers approved by the supplier of water and conforming to prior or subsequent editions of the standards cited in paragraph (A) of this rule, and which are properly maintained in accordance with paragraph (C) of this rule shall be excluded from the requirements of paragraphs (A) and (B) of this rule if the supplier of water and the director are assured that the backflow preventer will satisfactorily protect the public water system.

[Comment: This rule incorporates portions of the following manual by reference: The manual of cross-connection control, tenth edition, published by the foundation for cross-connection control and hydraulic research, university of Southern California. At the effective date of this rule, a copy of this document may be obtained from the foundation for cross-connection control and hydraulic research, university of Southern California, research annex 219, 3716 Hope Street, Los Angeles, CA 90089-7700, phone: 866-545-6340, world-wide web address: <http://www.usc.edu/dept/fccchr/>. This document is available for review at Ohio EPA, Lazarus government center, 50 West Town street, suite 700, Columbus, OH 43215.]

Replaces: 3745-95-06

Ohio Admin. Code 3745-95-06

Effective: 10/26/2015 Five Year Review (FYR) Dates: 10/26/2020 Promulgated Under: 119.03 Statutory Authority: 6109.04 Rule Amplifies: 6109.04, 6109.13 Prior Effective Dates: 07/01/72, 11/26/80, 05/01/03

### **Section 3745-95-07 - Booster pumps.**

(A) No person shall install or maintain a water service connection where a booster pump has been installed, unless an approved method is in place and is operational to maintain a minimum suction pressure as prescribed in the following:

(1) For booster pumps not intended to be used for fire suppression, no person shall install or maintain a water service connection to any premises where a booster pump has been installed on the service line to or within such premises, unless such booster pump is equipped with a low pressure cut-off designed to shut-off the

booster pump when the pressure in the service line on the suction side of the pump drops to ten pounds per square inch gauge or less.

**(2)** For booster pumps used for fire suppression, also referred to as fire pumps, no person shall install or maintain a water service connection to any premises where a fire pump has been installed on the service line to or within such premises, unless the pump is equipped with one of the following:

**(a)** A low suction throttling valve which is a pilot-operated valve installed in the discharge piping that maintains positive pressure in the suction piping, while monitoring pressure in the suction piping through a sensing line. The valve must throttle the discharge of the pump when necessary so that suction pressure will not be reduced below ten pounds per square inch gauge while the pump is operating.

**(b)** A variable speed suction limiting control which is a speed control system used to maintain a minimum positive suction pressure at the pump inlet by reducing the pump driver speed while monitoring pressure in the suction piping through a sensing line. It will be set so that the suction pressure will not be reduced below ten pounds per square inch gauge while the pump is operating.

**(3)** Booster pumps used for fire suppression, also referred to as fire pumps, installed prior to August 8, 2008, which are equipped with a low pressure cut-off as defined in paragraph (A)(1) of this rule, are not required to be modified solely for the purpose of meeting the new methods accepted after this date, under paragraph (A)(2) of this rule.

**(B)** The water consumer shall maintain the low-pressure cut-off device, the low suction throttling valve, or the variable speed suction limiting control in proper working order and certify to the supplier of water, at least once every twelve months that the minimum suction pressure sustaining method is operable and maintained in continuous operation.

**(C)** The supplier of water shall maintain electronic or paper records of inventory of booster pump installations. Electronic or paper records certifying operation must be retained for a period of five years.

**(D)** The provisions of this rule shall be followed notwithstanding inconsistent provisions in the " Great Lakes-Upper Mississippi River Board of State and Provincial Public Health and Environmental Managers' Recommended Standards for Water Works" (2012).

[Comment: "Recommended Standards for Water Works" 2012 edition. Copies are available from "Ohio EPA, Lazarus Government Center, 50 West Town Street, Suite 700, Columbus, OH 43215, (614) 644-2752" or online at <http://10statesstandards.com> or [www.epa.ohio.gov/ddagw](http://www.epa.ohio.gov/ddagw).]

Ohio Admin. Code 3745-95-07

Effective: 8/15/2018 Five Year Review (FYR) Dates: 5/16/2018 and 08/15/2023  
Promulgated Under: 119.03 Statutory Authority: 6109.04 Rule Amplifies: 6109.04,  
6109.13 Prior Effective Dates: 07/01/1972, 11/26/1980, 05/01/2003, 08/08/2008,  
10/26/2015

### **Section 3745-95-08 – Violations.**

(A) After reasonable notice to the occupant thereof, the supplier of water shall deny or discontinue the water service to any premises wherein any of the following occurs:

(1) A backflow preventer required by this chapter is not installed, tested and maintained in a manner acceptable to the supplier of water.

(2) The backflow preventer has been removed or by-passed.

(3) An unprotected cross-connection exists on the premises.

(4) A low-pressure cut-off, low suction throttling valve or variable speed suction limiting control, as required by rule 3745-95-07 of the Administrative Code, is not installed or maintained in working order.

(5) The supplier of water or the director, or the authorized representative of either, is denied entry to determine compliance with this chapter.

(B) Water service to such premises shall not be restored until the consumer has corrected or eliminated such conditions or defects in conformance with this chapter, and to the satisfaction of the supplier of water.

Ohio Admin. Code 3745-95-08

Effective: 8/15/2018 Five Year Review (FYR) Dates: 5/16/2018 and 08/15/2023  
Promulgated Under: 119.03 Statutory Authority: 6109.04 Rule Amplifies: 6109.03,  
6109.04.6109.13 Prior Effective Dates: 07/01/1972, 11/26/1980

**Section 3745-95-09 - Requirements for yard hydrants.**

(A) Yard hydrants with weep holes.

(1) Yard hydrants with weep holes used for human consumption installed on a public water system are prohibited unless the weep holes are sealed.

(2) Yard hydrants with weep holes not used for human consumption installed on a public water system, and those installed on a consumer's water system, shall have an appropriate backflow prevention assembly on the service line to protect the public water system. Yard hydrants with weep holes installed on public water systems shall be clearly labeled as "non-potable" or "not for human consumption."

(B) Sanitary yard hydrants that do not have weep holes, such as those that meet the requirements of the "American Society of Sanitary Engineers (ASSE) standard 1057, Performance Requirements for Freeze Resistant Yard Hydrants with Backflow Protection" (2001), are not prohibited provided:

(1) The device is acceptable to the public water system to which it will be connected; and

(2) Any other applicable backflow prevention and cross-connection control requirements of this chapter are met.

Ohio Admin. Code 3745-95-09

Five Year Review (FYR) Dates: 01/31/2017 and 01/31/2022 Promulgated Under:  
119.03 Statutory Authority: 6109.04 Rule Amplifies: 6109.04, 6109.13 Prior  
Effective Dates: 02/15/1951, 11/26/1980, 10/01/2006

Effective: 04/19/2012 R.C. 119.032 review dates: 09/28/2011 and 03/09/2017  
Promulgated Under: 119.03 Statutory Authority: 6109.04 Rule Amplifies: 6109.03,  
6109.04, 6109.13 Prior Effective Dates: 02/15/51, 11/26/80, 10/01/06

# APPENDIX D

## Ohio DOC Rules and Regulations

### Chapter 6 Water Supply and Distribution

#### 606.5.5 Low-Pressure Cutoff Required on Booster Pumps

*In accordance with rule 3745-95-07 of the Administrative Code, a low-pressure cutoff, a low suction throttling valve, or variable speed suction limiting controls shall be installed on all booster pumps in a water pressure booster system to prevent creation of a vacuum or negative pressure on the suction side of the pump when a positive pressure of 10 psi (68.94 kPa) or less occurs on the suction side of the pump while the pump is operating. Enforcement of the referenced rule is the responsibility of the local water supplier.*

### Section 608 Protection of Potable Water Supply

#### 608.1 General

A potable water supply system within a building shall be designed, installed and maintained in such a manner so as to prevent contamination from nonpotable liquids, solids or gases being introduced into the building potable water supply through cross-connections or any other piping connections to the system. Isolation backflow prevention device applications shall conform to Table 608.1, except as specifically stated in Sections 608.2 through 608.16.10.

TABLE 608.1

#### APPLICATION OF BACKFLOW PREVENTERS

DEVICE	DEGREE OF HAZARD <sup>a</sup>	APPLICATION <sup>b</sup>	APPLICABLE STANDARDS
Air gap	High or low hazard	Backsiphonage or backpressure	ASME A112.1.2
Air gap fittings for use with plumbing	High or low hazard	Backsiphonage or backpressure	ASME A112.1.3

fixtures, appliances and appurtenances			
Antisiphon-type fill valves for gravity water closet flush tanks	High hazard	Backsiphonage only	ASSE 1002, CSA B125.3
Backflow preventer for carbonated beverage machines	Low hazard	Backpressure or backsiphonage Sizes $\frac{1}{4}$ " - $\frac{3}{8}$ "	ASSE 1022
Backflow preventer with intermediate atmospheric vents	Low hazard	Backpressure or backsiphonage Sizes $\frac{1}{4}$ " - $\frac{3}{4}$ "	ASSE 1012, CAN/CSA B64.3
Barometric loop	High or low hazard	Backsiphonage only	(See Section 608.13.4)
Double check backflow prevention assembly and double check fire protection backflow prevention assembly	Low hazard	Backpressure or backsiphonage Sizes $\frac{3}{8}$ " - 16"	ASSE 1015, AWWA C510, CSA B64.5, CSA B64.5.1
Double check detector fire protection backflow prevention assemblies	Low hazard	Backpressure or backsiphonage (Fire sprinkler systems) Sizes 2" - 16"	ASSE 1048
Dual-check-valve-type backflow preventer	Low hazard	Backpressure or backsiphonage Sizes $\frac{1}{4}$ " - 1"	ASSE 1024, CSA B64.6
Hose connection backflow preventer	High or low hazard	Low head backpressure, rated working pressure, backpressure or backsiphonage Sizes $\frac{1}{2}$ " - 1"	ASSE 1052, CSA B64.2.1.1
Hose connection vacuum breaker	High or low hazard	Low head backpressure or	ASSE 1011, CAN/CSA B64.2, CSA B64.2.1

		backsiphonage Sizes $\frac{1}{2}$ ", $\frac{3}{4}$ ", 1"	
Laboratory faucet backflow preventer	High or low hazard	Low head backpressure and backsiphonage	ASSE 1035, CSA B64.7
Pipe-applied atmospheric-type vacuum breaker	High or low hazard	Backsiphonage only Sizes $\frac{1}{4}$ "- 4"	ASSE 1001, CAN/CSA B64.1.1
Pressure vacuum breaker assembly	High or low hazard	Backsiphonage only Sizes $\frac{1}{2}$ "- 2"	ASSE 1020, CSA B64.1.2
Reduced pressure principle backflow preventer and reduced pressure principle fire protection backflow preventer	High or low hazard	Backpressure or backsiphonage Sizes $\frac{3}{8}$ "- 16"	ASSE 1013, AWWA C511, CAN/CSA B64.4, CSA B64.4.1
Reduced pressure detector fire protection backflow prevention assemblies	High or low hazard	Backsiphonage or backpressure (Fire sprinkler systems)	ASSE 1047
Spillproof vacuum breaker	High or low hazard	Backsiphonage only Sizes $\frac{1}{4}$ "-2"	ASSE 1056
Vacuum breaker wall hydrants, frost-resistant, automatic draining type	High or low hazard	Low head backpressure or backsiphonage Sizes $\frac{3}{4}$ ", 1"	ASSE 1019, CAN/CSA B64.2.2

For SI: 1 inch = 25.4 mm.

1. Low hazard—See Pollution (Section 202).  
High hazard—See Contamination (Section 202).



2.

See Backpressure (Section 202).

See Backpressure, low head (Section 202).

See Backsiphonage (Section 202).

<b>DEVICE</b>	<b>Installation</b>	<b>APPLICABLE STANDARDS</b>
Air gap	Should be used whenever possible, is the only absolute means of preventing backflow.	Lavatories, process tanks, sinks, bathtubs, and cooling towers.
Pipe-applied atmospheric-type vacuum breaker	May not have a downstream valve since this device is not designed to operate under continuous pressure.	Irrigation systems, process tanks, dishwashers, and soap dispensers.
Antisiphon-type fill valves for gravity water closet flush tanks	Tank type water closet or flush tank for urinals.	Water closet or flush type urinals.
Backflow preventer for carbonated beverage machines	Low head backpressure in intended to mean negligible backpressure in the 1.0 psi to 4.0 psi range, no continuous pressure over 12 hrs.	Hose bibb connections
Backflow preventer with intermediate atmospheric vents	Low hazard cross-connections under continuous pressure, but may not be subject to backpressure	Residential boilers or cooling towers containing no additives
Reduced pressure principle backflow preventer	Cross-connections subject to backsiphonage or backpressure and operating under continuous pressure	Main supply lines, commercial or chemically treated boilers or chillers, main hospital lines and

		equipment, tanks with submerged inlets
Reduced pressure principle fire protection backflow preventer	Installed on a fire protection system containing any additive, even a food-grade additive	Chemically charged fire protection systems (such as Foamite), or a fire protection system that contains any additive or anti-freeze
Double check backflow prevention assembly	Installed to prevent the backflow of a substance that would not present a hazard to health	Main supply lines, food cookers, tanks or vats containing non-toxic substances
Double check detector check assembly	Installed on a fire protection system that contains only the public water, has no booster pump, storage, or auxiliary water	Non-chemically charged and/or non-toxic fire protection systems; a fire sprinkler system that is filled with water from the public water supply
Frost proof wall hydrant, Automatic draining	Low head backpressure is intended to mean negligible backpressure in the 1.0 psi to 4.0 psi range, no continuous pressure over 12 hrs.	Wall hydrant hose bibb
Pressure vacuum breaker	Continuous pressure is OK because the air-inlet and check valve are spring-loaded	Irrigation systems, plating tanks, livestock watering systems, supply to a submerged inlet
Backflow preventer for carbonated beverage machines	Constructed of non-copper material	Installed inside the post-mix type carbonated beverage dispensers, by the beverage maintenance personnel
Dual check valve type backflow preventer	Low hazard cross-connections, continuous pressure, backsiphonage and backpressure	Residential water service connections, individual outlets
Dual check valve type backflow preventer	Usually a ball-type check valve	Installed inside a post-mix type carbonated beverage

for Post-mix beverage dispenser		dispensers, by the beverage maintenance personnel
Laboratory faucet vacuum breaker	Low head backpressure is intended to mean negligible backpressure in the 1.0 psi to 4.0 psi range, no continuous pressure over 12 hrs	Laboratory faucets
Hose connection vacuum breaker	Low head backpressure is intended to mean negligible backpressure in the 1.0 psi to 4.0 psi range, no continuous pressure over 12 hrs	Hose bibb connections
Backsiphonage, Spill proof vacuum breaker	Used in areas where water spillage may present a problem	X-ray or photo developing machines

## 608.2 Plumbing Fixtures

The supply lines and fittings for every plumbing fixture shall be installed so as to prevent backflow. Plumbing fixture fittings shall provide backflow protection in accordance with ASME A112.18.1.

## 608.3 Devices, Appurtenances, Appliances and Apparatus

All devices, appurtenances, appliances and apparatus intended to serve some special function, such as sterilization, distillation, processing, cooling, or storage of ice or foods, and that connect to the water supply system, shall be provided with protection against backflow and contamination of the water supply system. Water pumps, *water-powered sump pumps*, filters, softeners, tanks and all other appliances and devices that handle or treat potable water shall be protected against contamination.

### 608.3.1 Special Equipment, Water Supply Protection

The water supply for hospital fixtures shall be protected against backflow with a reduced pressure principle backflow preventer, an atmospheric or spill-proof

vacuum breaker, or an air gap. Vacuum breakers for bedpan washer hoses shall not be located less than 5 feet (1524 mm) above the floor. Vacuum breakers for hose connections in health care or laboratory areas shall not be less than 6 feet (1829 mm) above the floor.

#### **608.4 Water Service Piping**

Water service piping shall be protected in accordance with Sections 603.2 and 603.2.1.

#### **608.5 Chemicals and Other Substances**

Chemicals and other substances that produce either toxic conditions, taste, odor or discoloration in a potable water system shall not be introduced into, or utilized in, such systems.

#### **608.6 Cross-Connection Control**

Cross connections shall be prohibited, except where approved protective devices are installed.

##### **608.6.1 Private Water Supplies**

Cross connections between a private water supply and a potable public supply shall be prohibited.

#### **608.7 Valves and Outlets Prohibited Below Grade**

Potable water outlets and combination stop-and-waste valves shall not be installed underground or below grade. Freezeproof yard hydrants that drain the riser into the ground are considered to be stop-and-waste valves.

**Exception:** Freezeproof yard hydrants that drain the riser into the ground shall be permitted to be installed, provided that the potable water supply to such hydrants is protected upstream of the hydrants in accordance with Section 608 and the hydrants are permanently identified as nonpotable outlets by approved signage that reads as follows: "Caution, Nonpotable Water. Do Not Drink."

## **608.8 Identification of Nonpotable Water**

In buildings where nonpotable water systems are installed, the piping conveying the nonpotable water shall be identified either by color marking or metal tags in accordance with Sections 608.8.1 through 608.8.3. All nonpotable water outlets such as hose connections, open ended pipes, and faucets shall be identified at the point of use for each outlet with the words, "Nonpotable—not safe for drinking." The words shall be indelibly printed on a tag or sign constructed of corrosion-resistant waterproof material or shall be indelibly printed on the fixture. The letters of the words shall be not less than 0.5 inches in height and color in contrast to the background on which they are applied.

### **608.8.1 Information**

Pipe identification shall include the contents of the piping system and an arrow indicating the direction of flow. Hazardous piping systems shall also contain information addressing the nature of the hazard. Pipe identification shall be repeated at maximum intervals of 25 feet (7620 mm) and at each point where the piping passes through a wall, floor or roof. Lettering shall be readily observable within the room or space where the piping is located.

### **608.8.2 Color**

The color of the pipe identification shall be discernable and consistent throughout the building. The color purple shall be used to identify reclaimed, rain and gray water distribution systems.

### **608.8.3 Size**

The size of the background color field and lettering shall comply with Table 608.8.3.

TABLE 608.8.3

SIZE OF PIPE IDENTIFICATION

PIPE DIAMETER (inches)	LENGTH BACKGROUND COLOR FIELD (inches)	SIZE OF LETTERS (inches)
$\frac{3}{4}$ to $1\frac{1}{4}$	8	0.5
$1\frac{1}{2}$ to 2	8	0.75
$2\frac{1}{2}$ to 6	12	1.25
8 to 10	24	2.5
over 10	32	3.5

For SI: 1 inch = 25.4 mm.

**608.9 Reutilization Prohibited**

Water utilized for the cooling of equipment or other processes shall not be returned to the potable water system. Such water shall be discharged into a drainage system through an air gap or shall be utilized for nonpotable purposes.

**608.10 Reuse of Piping**

Piping that has been utilized for any purpose other than conveying potable water shall not be utilized for conveying potable water.

**608.11 Painting of Water Tanks**

The interior surface of a potable water tank shall not be lined, painted or repaired with any material that changes the taste, odor, color or potability of the water supply when the tank is placed in, or returned to, service.

**608.12 Pumps and Other Appliances**

Water pumps, *water-powered sump pumps*, filters, softeners, tanks and all other devices that handle or treat potable water shall be protected against contamination.

**608.13 Backflow Protection**

Means of protection against backflow shall be provided in accordance with Sections 608.13.1 through 608.13.9.

### **608.13.1 Air Gap**

The minimum required air gap shall be measured vertically from the lowest end of a potable water outlet to the flood level rim of the fixture or receptacle into which such potable water outlet discharges. Air gaps shall comply with ASME A112.1.2 and air gap fittings shall comply with ASME A112.1.3.

### **608.13.2 Reduced Pressure Principle Backflow Preventers**

Reduced pressure principle backflow preventers shall conform to ASSE 1013, AWWA C511, CAN/CSA B64.4 or CSA B64.4.1. Reduced pressure detector assembly backflow preventers shall conform to ASSE 1047. These devices shall be permitted to be installed where subject to continuous pressure conditions. The relief opening shall discharge by air gap and shall be prevented from being submerged.

### **608.13.3 Backflow Preventer With Intermediate Atmospheric Vent**

Backflow preventers with intermediate atmospheric vents shall conform to ASSE 1012 or CAN/CSA B64.3. These devices shall be permitted to be installed where subject to continuous pressure conditions. The relief opening shall discharge by air gap and shall be prevented from being submerged.

### **608.13.4 Barometric Loop**

Barometric loops shall precede the point of connection and shall extend vertically to a height of 35 feet (10 668 mm). A barometric loop shall only be utilized as an atmospheric-type or pressure-type vacuum breaker.

### **608.13.5 Pressure-Type Vacuum Breakers**

Pressure-type vacuum breakers shall conform to ASSE 1020 or CSA B64.1.2 and spill proof vacuum breakers shall comply with ASSE 1056. These devices are designed for installation under continuous pressure conditions when the critical level is installed at the required height. Pressure-type vacuum breakers shall not be installed in locations where spillage could cause damage to the structure.

### **608.13.6 Atmospheric-Type Vacuum Breakers**

Pipe applied atmospheric-type vacuum breakers shall conform to ASSE 1001 or CAN/CSA B64.1.1. Hose-connection vacuum breakers shall conform to ASSE 1011, ASSE 1019, ASSE 1035, ASSE 1052, CAN/CSA B64.2, CSA B64.2.1, CSA B64.2.1.1, CAN/CSA B64.2.2 or CSA B64.7. These devices shall operate under normal atmospheric pressure when the critical level is installed at the required height.

### **608.13.7 Double Check-Valve Assemblies**

Double check-valve assemblies shall conform to ASSE 1015, CSA B64.5, CSA B64.5.1 or AWWA C510. Double-detector check-valve assemblies shall conform to ASSE 1048. These devices shall be capable of operating under continuous pressure conditions.

### **608.13.8 Spillproof Vacuum Breakers**

Spillproof vacuum breakers (SVB) shall conform to ASSE 1056. These devices are designed for installation under continuous-pressure conditions when the critical level is installed at the required height.

### **608.13.9 Chemical Dispenser Backflow Devices**

Backflow devices for chemical dispensers shall comply with ASSE 1055 or shall be equipped with an air gap fitting.

### **608.14 Location of Backflow Preventers**

Access shall be provided to backflow preventers as specified by the installation instructions of the approved manufacturer.

#### **608.14.1 Outdoor Enclosures for Backflow Prevention Devices**

Outdoor enclosures for backflow prevention devices shall comply with ASSE 1060.



## 608.14.2 Protection of Backflow Preventers

Backflow preventers shall not be located in areas subject to freezing except where they can be removed by means of unions or are protected from freezing by heat, insulation or both.

### 608.14.2.1 Relief Port Piping

The termination of the piping from the relief port or air gap fitting of a backflow preventer shall discharge to an approved indirect waste receptor or to the outdoors where it will not cause damage or create a nuisance.

## 608.15 Protection of Potable Water Outlets

All potable water openings and outlets shall be protected against backflow in accordance with Section 608.15.1, 608.15.2, 608.15.3, 608.15.4, 608.15.4.1 or 608.15.4.2.

### 608.15.1 Protection by Air Gap

Openings and outlets shall be protected by an air gap between the opening and the fixture flood level rim as specified in Table 608.15.1. Openings and outlets equipped for hose connection shall be protected by means other than an air gap.

TABLE 608.15.1

#### MINIMUM REQUIRED AIR GAPS

FIXTURE	MINIMUM AIR GAP	
	Away from a wall <sup>a</sup> (inches)	Close to a wall (inches)
Lavatories and other fixtures with effective opening not greater than $\frac{1}{2}$ inch in diameter	1	$1\frac{1}{2}$
Sink, laundry trays, gooseneck back faucets and other fixtures with effective openings not greater than $\frac{3}{4}$ inch in diameter	$1\frac{1}{2}$	$2\frac{1}{2}$

Over-rim bath fillers and other fixtures with effective openings not greater than 1 inch in diameter	2	3
Drinking water fountains, single orifice not greater than $\frac{7}{16}$ inch in diameter or multiple orifices with a total area of 0.150 square inch (area of circle $\frac{7}{16}$ inch in diameter)	1	1 $\frac{1}{2}$
Effective openings greater than 1 inch	Two times the diameter of the effective opening	Three times the diameter of the effective opening

For SI: 1 inch = 25.4 mm.

1. Applicable where walls or obstructions are spaced from the nearest inside-edge of the spout opening a distance greater than three times the diameter of the effective opening for a single wall, or a distance greater than four times the diameter of the effective opening for two intersecting walls.

#### **608.15.2 Protection by a Reduced Pressure Principle Backflow Preventer**

Openings and outlets shall be protected by a reduced pressure principle backflow preventer.

#### **608.15.3 Protection by a Backflow Preventer With Intermediate Atmospheric Vent**

Openings and outlets shall be protected by a backflow preventer with an intermediate atmospheric vent.

#### **608.15.4 Protection by a Vacuum Breaker**

Openings and outlets shall be protected by atmospheric-type or pressure-type vacuum breakers. The critical level of the vacuum breaker shall be set a minimum of 6 inches (152 mm) above the flood level rim of the fixture or device. Fill valves shall be set in accordance with Section 425.3.1. Vacuum breakers shall not be installed under exhaust hoods or similar locations that will contain toxic fumes or vapors. Pipe-applied vacuum breakers shall be installed not less than 6 inches (152

mm) above the flood level rim of the fixture, receptor or device served.

#### **608.15.4.1 Deck-Mounted and Integral Vacuum Breakers**

Approved deck-mounted or equipment-mounted vacuum breakers and faucets with integral atmospheric or spillproof vacuum breakers shall be installed in accordance with the manufacturer's instructions and the requirements for labeling with the critical level not less than 1 inch (25 mm) above the flood level rim.

#### **608.15.4.2 Hose Connections**

Sillcocks, hose bibbs, wall hydrants and other openings with a hose connection shall be protected by an atmospheric-type or pressure-type vacuum breaker or a permanently attached hose connection vacuum breaker.

#### **Exceptions:**

1. This section shall not apply to water heater and boiler drain valves that are provided with hose connection threads and that are intended only for tank or vessel draining.
2. This section shall not apply to water supply valves intended for connection of clothes washing machines where backflow prevention is otherwise provided or is integral with the machine.

### **608.16 Connections to the Potable Water System**

Connections to the potable water system shall conform to Sections 608.16.1 through 608.16.10.

#### **608.16.1 Beverage Dispensers**

The water supply connection to beverage dispensers shall be protected against backflow by a backflow preventer conforming to ASSE 1022 or by an air gap. The portion of the backflow preventer device downstream from the second check valve and the piping downstream therefrom shall not be affected by carbon dioxide gas.

#### **608.16.2 Connections to Boilers**

The potable supply to the boiler shall be equipped with a backflow preventer with an intermediate atmospheric vent complying with ASSE 1012 or CAN/CSA B64.3.

Where conditioning chemicals are introduced into the system, the potable water connection shall be protected by an air gap or a reduced pressure principle backflow preventer, complying with ASSE 1013, CAN/CSA B64.4 or AWWA C511.

### **608.16.3 Heat Exchangers**

Heat exchangers utilizing an essentially toxic transfer fluid shall be separated from the potable water by double-wall construction. An air gap open to the atmosphere shall be provided between the two walls. Heat exchangers utilizing an essentially nontoxic transfer fluid shall be permitted to be of single-wall construction.

### **608.16.4 Connections to Automatic Fire Sprinkler Systems and Standpipe Systems**

The potable water supply to automatic fire sprinkler and standpipe systems shall be protected against backflow by a double check-valve assembly or a reduced pressure principle backflow preventer.

#### **Exceptions:**

1. Where systems are installed as a portion of the water distribution system in accordance with the requirements of this code and are not provided with a fire department connection, isolation of the water supply system shall not be required.
2. Isolation of the water distribution system is not required for deluge, preaction or dry pipe systems.

#### **608.16.4.1 Additives or Nonpotable Source**

Where systems under continuous pressure contain chemical additives or antifreeze, or where systems are connected to a nonpotable secondary water supply, the potable water supply shall be protected against backflow by a reduced pressure principle backflow preventer. Where chemical additives or antifreeze are added to only a portion of an automatic fire sprinkler or standpipe system, the reduced pressure principle backflow preventer shall be permitted to be located so as to isolate that portion of the system. Where systems are not under continuous pressure, the potable water supply shall be protected against backflow by an air gap or a pipe applied atmospheric vacuum breaker conforming to ASSE 1001 or CAN/CSA B64.1.1.

### **608.16.5 Connections to Lawn Irrigation Systems**

The potable water supply to lawn irrigation systems shall be protected against backflow by an atmospheric-type vacuum breaker, a pressure-type vacuum breaker or a reduced pressure principle backflow preventer. A valve shall not be installed downstream from an atmospheric vacuum breaker. Where chemicals are introduced into the system, the potable water supply shall be protected against backflow by a reduced pressure principle backflow preventer.

### **608.16.6 Connections Subject to Backpressure**

Where a potable water connection is made to a nonpotable line, fixture, tank, vat, pump or other equipment subject to backpressure, the potable water connection shall be protected by a reduced pressure principle backflow preventer.

### **608.16.7 Chemical Dispensers**

Where chemical dispensers connect to the potable water distribution system, the water supply system shall be protected against backflow in accordance with Section 608.13.1, 608.13.2, 608.13.5, 608.13.6, 608.13.8 or 608.13.9.

### **608.16.8 Portable Cleaning Equipment**

Where the portable cleaning equipment connects to the water distribution system, the water supply system shall be protected against backflow in accordance with Section 608.13.1, 608.13.2, 608.13.3, 608.13.7 or 608.13.8.

### **608.16.9 Dental Pump Equipment**

Where dental pumping equipment connects to the water distribution system, the water supply system shall be protected against backflow in accordance with Section 608.13.1, 608.13.2, 608.13.5, 608.13.6 or 608.13.8.

### **608.16.10 Coffee Machines and Noncarbonated Beverage Dispensers**

The water supply connection to coffee machines and noncarbonated beverage dispensers shall be protected against backflow by a backflow preventer conforming to ASSE 1022 or by an air gap.

## **608.17 Protection of Individual Water Supplies**

An individual water supply, *otherwise known as a private water system*, shall be located and constructed so as to be safeguarded against contamination in accordance with *the rules of the "Ohio Department of Health" contained within Chapter 3701-28 of the Administrative Code, "Private Water Systems."*

### **608.17.1 Well Locations**

*Deleted.*

#### **Table 608.17.1 Distance from Contamination to Private Water Supplies and Pump Suction Lines.**

*Deleted.*

### **608.17.2 Elevation**

*Deleted.*

### **608.17.3 Depth**

*Deleted.*

### **608.17.4 Water-Tight Casings**

*Deleted.*

### **608.17.5 Drilled or Driven Well Casings**

*Deleted.*

### **608.17.6 Dug or Bored Well Casings**

*Deleted.*

### **608.17.7 Cover**

*Deleted.*

## **608.17.8 Drainage**

*Deleted.*

## **Section 609 Health Care Plumbing**

### **609.1 Scope**

This section shall govern those aspects of health care plumbing systems that differ from plumbing systems in other structures. Health care plumbing systems shall conform to the requirements of this section in addition to the other requirements of this code. The provisions of this section shall apply to the special devices and equipment installed and maintained in the following occupancies: nursing homes, homes for the aged, orphanages, infirmaries, first aid stations, psychiatric facilities, clinics, professional offices of dentists and doctors, mortuaries, educational facilities, surgery, dentistry, research and testing laboratories, establishments manufacturing pharmaceutical drugs and medicines, and other structures with similar apparatus and equipment classified as plumbing.

### **609.2 Water Service**

All hospitals shall have two water service pipes installed in such a manner so as to minimize the potential for an interruption of the supply of water in the event of a water main or water service pipe failure.

### **609.3 Hot Water**

Hot water shall be provided to supply all of the hospital fixture, kitchen and laundry requirements. Special fixtures and equipment shall have hot water supplied at a temperature specified by the manufacturer. The hot water system shall be installed in accordance with Section 607.

### **609.4 Vacuum Breaker Installation**

Vacuum breakers shall be installed a minimum of 6 inches (152 mm) above the flood level rim of the fixture or device in accordance with Section 608. The flood level rim of hose connections shall be the maximum height at which any hose is utilized.

### **609.5 Prohibited Water Closet and Clinical Sink Supply**

Jet-or water-supplied orifices, except those supplied by the flush connections, shall not be located in or connected with a water closet bowl or clinical sink. This section shall not prohibit an approved bidet installation.

### **609.6 Clinical, Hydrotherapeutic and Radiological Equipment**

All clinical, hydrotherapeutic, radiological or any equipment that is supplied with water or that discharges to the waste system shall conform to the requirements of this section and Section 608.

### **609.7 Condensate Drain Trap Seal**

A water supply shall be provided for cleaning, flushing and resealing the condensate trap, and the trap shall discharge through an air gap in accordance with Section 608.

### **609.8 Valve Leakage Diverter**

Each water sterilizer filled with water through directly connected piping shall be equipped with an approved leakage diverter or bleed line on the water supply control valve to indicate and conduct any leakage of unsterile water away from the sterile zone.

## **Section 610 Disinfection of Potable Water System**

### **610.1 General**

New or repaired potable water systems shall be purged of deleterious matter and disinfected prior to utilization. The method to be followed shall be that prescribed by the health authority or water purveyor having jurisdiction or, in the absence of a prescribed method, the procedure described in either AWWA C651 or AWWA C652, or as described in this section. This requirement shall apply to "on-site" or "in-plant" fabrication of a system or to a modular portion of a system.

1. The pipe system shall be flushed with clean, potable water until dirty water does not appear at the points of outlet.
2. The system or part thereof shall be filled with a water/ chlorine solution containing at least 50 parts per million (50 mg/L) of chlorine, and the system



or part thereof shall be valved off and allowed to stand for 24 hours; or the system or part thereof shall be filled with a water/ chlorine solution containing at least 200 parts per million (200 mg/L) of chlorine and allowed to stand for 3 hours.

3. Following the required standing time, the system shall be flushed with clean potable water until the chlorine is purged from the system.
4. The procedure shall be repeated where shown by a bacteriological examination that contamination remains present in the system.

## **Section 611 Drinking Water Treatment Units**

### **611.1 Design**

Drinking water treatment units shall meet the requirements of NSF 42, NSF 44, NSF 53, NSF 62 or CSA B483.1.

### **611.2 Reverse Osmosis Systems**

The discharge from a reverse osmosis drinking water treatment unit shall enter the drainage system through an air gap or an air gap device that meets the requirements of NSF 58 or CSA B483.1.

### **611.3 Connection Tubing**

The tubing to and from drinking water treatment units shall be of a size and material as recommended by the manufacturer. The tubing shall comply with NSF 14, NSF 42, NSF 44, NSF 53, NSF 58 or NSF 61.

## **Section 612 Solar Systems**

### **612.1 Solar Systems**

The construction, installation, alterations and repair of systems, equipment and appliances intended to utilize solar energy for space heating or cooling, domestic hot water heating, swimming pool heating or process heating shall be in accordance with the mechanical code.

## **Section 613 Temperature Control Devices and Valves**

### **613.1 Temperature-Actuated Mixing Valves**

Temperature-actuated mixing valves, which are installed to reduce water temperatures to defined limits, shall comply with ASSE 1017. Such valves shall be installed at the hot water source.

#### **Approved Ohio DOC backflow prevention devices**

The Ohio Department of Commerce, Industrial Compliance Division recognizes those backflow prevention devices that have obtained the American Society of Sanitary Engineering (ASSE) seal authorization approval, for use as an isolation principle backflow prevention protection.

The ASSE Standard Number will be stamped into the body of the device or printed on a metal plate that is attached the device.

The ASSE seal authorization approval list may be viewed at [www.asse-plumbing.org](http://www.asse-plumbing.org).

In order to select the appropriate backflow prevention device for an application, it is necessary that you understand the appropriate application and limitations of the various devices.

The following informational charts indicate the devices that are accepted as isolation principle backflow prevention protection and their application.

#### **Installation Requirements**

Proper installation of backflow prevention devices shall meet all local codes and regulations.

The local water supplier normally determines the installation requirements for a containment backflow prevention assembly. The following are a few typical requirements.

- The device must be approved by the local water supplier
- Should be installed in a horizontal position except those that are approved for a vertical installation (but you should be attentive to whether it should be vertical up or down)
- Should be 12” to 36” off of the floor

- Test cocks should be facing into the room if they are side-mounted on the device
- Must be installed in an area free of noxious fumes (for tester safety)
- An ASSE 1013 or 1047 may not be installed in a pit (due to possibility of flooding of the pit)
- You may not make a direct connection to the relief valve on an ASSE 1013
- As ASSE 1015 or 1048 may be installed in a pit if approved by the local water supplier
- You may not install an unprotected bypass around any backflow prevention device

The Ohio plumbing code and the local plumbing inspection authorities determine the installation requirement for an installation backflow prevention device.

Since there are few rules regarding the installation of isolation principle devices and if there are no requirements by the local Plumbing authorities, the Plumbing Unit of the Ohio Department of Commerce suggests that you install an isolation device in accordance with the manufacturer's recommendations.

For all approved Ohio DOC backflow prevention devices see pages 180-183.

## Approved Ohio DOC backflow prevention devices

Atmospheric Vacuum Breaker  
ASSE 1001 High/Low Hazard Backsiphonage Only

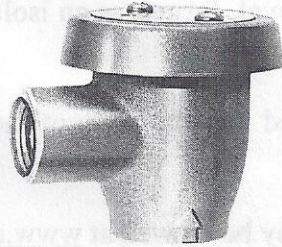

Water Closet Ballcock  
ASSE 1002 High/Low Hazard Backsiphonage Only

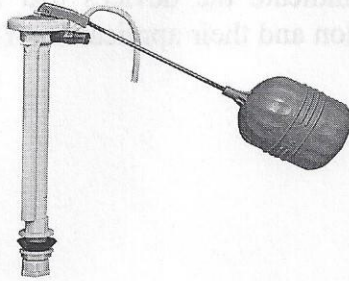

Hose Connection Vacuum Breaker  
ASSE 1011 High/Low Hazard Backsiphonage & Low-Head Backpressure



Backflow Preventer with Intermediate Atmospheric Vent  
ASSE 1012 Low Hazard Only Backsiphonage & Backpressure

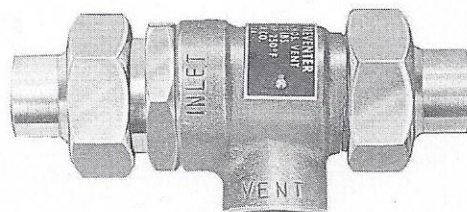

Reduced Pressure Principle Backflow Preventer  
ASSE 1013 High/Low Hazard Backsiphonage & Backpressure

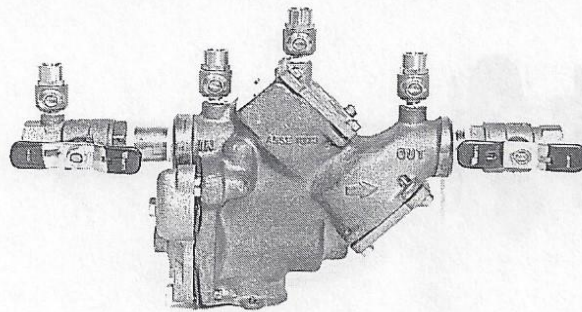

Reduced Pressure Principle Detector Check Assembly  
ASSE 1047 High/Low Hazard Backsiphonage & Backpressure Fire Systems

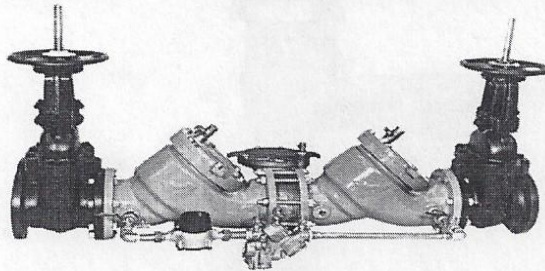

Double Check Valve Assembly  
ASSE 1015 Low Hazard Only Backsiphonage & Backpressure

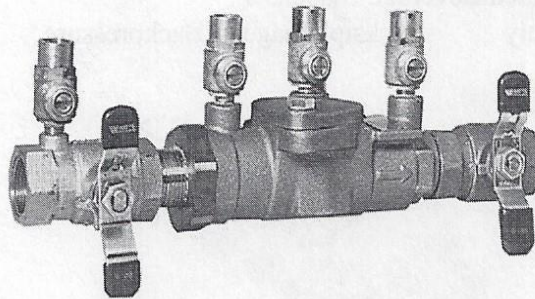

Double Check Detector Check Assembly  
ASSE 1048 Low Hazard Only Backsiphonage & Backpressure Fire Systems

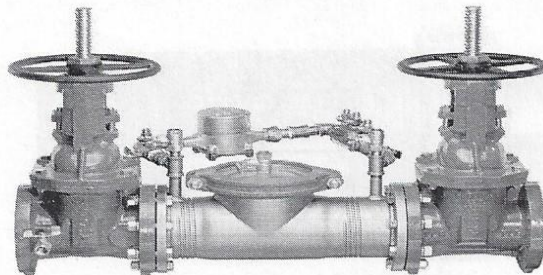

Frost Proof Wall Hydrant, Automatic Draining  
ASSE 1019 High/Low Hazard Backsiphonage & Low Head Backpressure

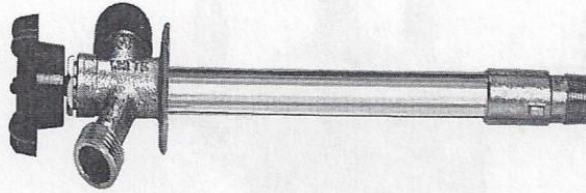

Pressure Vacuum Breaker  
ASSE 1020 High/Low Hazard Backsiphonage Only

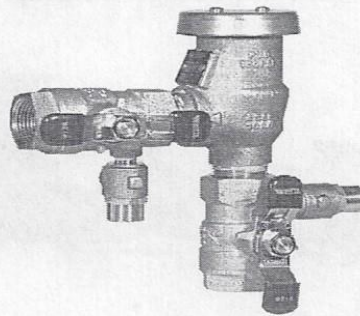

Backflow Preventer for Carbonated Beverage Dispenser  
ASSE 1022 Low Hazard Only Backsiphonage & Backpressure

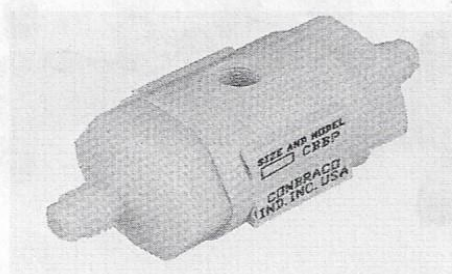

Dual Check Valve  
ASSE 1024 Low Hazard Only Backsiphonage & Backpressure

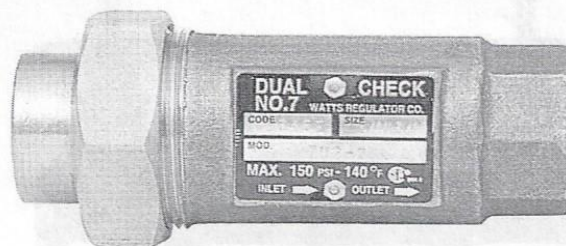

Lab Faucet Vacuum Breaker  
ASSE 1035 High/Low Hazard

Backsiphonage & Low Head Backpressure



Hose Connection Vacuum Breaker  
ASSE 1052 High/Low Hazard

Backsiphonage & Low Head Backpressure

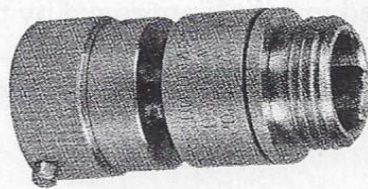

Backsiphonage Vacuum Breaker, Spill-Proof

ASSE 1056 High/Low Hazard

Backsiphonage Only

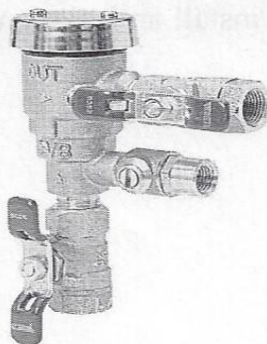

# **APPENDIX E**

## **3745-9-10 Abandoned well sealing.**

(A) An abandoned well shall be sealed in accordance with this rule and rule [3745-9-07](#) of the Administrative Code.

(1) "The State of Ohio Regulations and Technical Guidance For Sealing Unused Water Wells and Boreholes (2015)" shall be used as a guide.

(2) Plan approval is not required in accordance with Chapter 3745-91 of the Administrative Code to seal an abandoned well, test hole or dry hole. A public water system may apply to the director for a variance from this rule in accordance with rule [3745-9-02](#) of the Administrative Code.

(B) A test hole shall either be permanently sealed or converted into a well upon completion of testing.

(C) An abandoned well shall be sealed in accordance with the following:

(1) All obstructions shall be removed from the abandoned well, including the pump and related equipment, drop pipe, pit less adapter, suction line, trash or other debris. Unless permanently attached, all liner pipe shall be removed from the well prior to placement of sealing materials.

(2) Casing shall be removed, ripped or perforated, or with prior consultation with the district office the casing may be left intact or in place.

(a) Casing shall be removed to a depth of at least three feet below ground surface, except for a dug or bucket augured well covered by paragraph (C)(13)(b)(ii) of this rule. The remaining borehole shall be filled with clean clay.

(b) If possible, casing shall be removed by over drilling when the annular seal is inadequate, or water is flowing from around the outside of the casing, or gravel packing connects two or more hydraulic zones.

(3) Where evidence of microbiological growth is present, an abandoned well shall be disinfected by slowly wetting the casing or borehole with a solution of sodium hypochlorite or calcium hypochlorite. Disinfectant concentration in the water column shall be at least fifty milligrams per liter total chlorine.

(a) Disinfectant shall have standard ANSI/NSF 60 certification. .

(b) Contact of disinfectant with bentonite shall be avoided.

(4) Cement grout may be gravity poured into a dry hole where no water is present.



(5) After the sealing material and grout have been placed into the abandoned well, the grout shall cure a minimum of twelve hours to assess whether any settling of the sealing material has occurred. If settling has occurred, then additional grout shall be placed into the remaining borehole.

(6) The finished grade shall ensure that surface water runoff drains away from the sealed abandoned well.

(7) An abandoned well that is less than two hundred feet deep and greater than four inches in diameter may be sealed using coarse grade bentonite.

(8) An abandoned well that is less than one hundred feet deep and greater than four inches in diameter may be sealed using pelletized bentonite or coarse grade bentonite.

(9) An abandoned well that is constructed into or through a single aquifer that is not flowing at the surface shall be sealed in accordance with the following:

(a) Clean and disinfected sand or gravel may be placed either from the bottom of the abandoned well to the top of the aquifer, or to twenty-five feet below ground surface, whichever is encountered first.

(b) An abandoned well shall be sealed by either pressure grouting, or pouring coarse grade bentonite from twenty-five feet below ground surface to the ground surface.

(c) If casing is removed, sealing material and grout shall be placed while casing is being removed from the borehole.

(10) An abandoned well that is constructed into or through multiple aquifers that is not flowing at the surface shall be sealed in accordance with the following requirements:

(a) An abandoned well shall be sealed by pressure grouting.

(b) Pelletized bentonite or coarse grade bentonite may be poured.

(c) If detailed construction and geologic data is available, then clean and disinfected sand or gravel may be placed adjacent to the aquifer zones and grout placed adjacent to the confining units. The abandoned well shall then be sealed from the top of the uppermost aquifer or from twenty-five feet below ground surface, whichever is encountered first, to the surface with either cement grout or bentonite grout.

(11) An abandoned well that is flowing shall be sealed in accordance with the following requirements:

(a) If practical, the casing may be extended until the flow of water over the top of the casing stops. An abandoned well shall be sealed by pressure grouting, or coarse grade or pelletized bentonite may be poured.

(b) If casing extension is impractical because of the hydraulic head, one of the following shall be met:

(i) An inflatable packer shall be installed at the top of the producing formation to stop or restrict the flow of water. The abandoned well shall be sealed by pressure grouting through the packer from the bottom of the hole to the bottom of the packer. The packer shall then be deflated and pressure grouting shall continue to the ground surface.

(ii) A shut-in device shall be installed at the top of the abandoned well to prevent flow. A conductor pipe shall be inserted through the shut-in device and the abandoned well shall be sealed by pressure grouting from the bottom of the hole to the ground surface.

(iii) Disinfected gravel shall be poured into the abandoned well to reduce the flow of water and the abandoned well shall be sealed by pressure grouting from the top of the aquifer, or from twenty-five feet below ground surface, whichever is encountered first.

(iv) If additives are used to increase the density of cement grout to control the flow of water, appropriate placement techniques shall be used to ensure that separation does not occur .

(12) An abandoned well drilled through fractured or cavernous formations or a mine shaft, shall be sealed in accordance with the following:

(a) The depth and thickness of the fractured, cavernous zone or mine shaft shall be determined, if possible, and the fractured, cavernous zone or mine shaft shall be sealed in accordance with the following:

(i) Where the fractured, cavernous zone or mine shaft is greater than twenty-five feet from the ground surface, a packer, shale trap, or another similar device shall be installed at the top of the fractured, cavernous zone or mine shaft and the well shall then be sealed by pressure grouting up to the ground surface. In lieu of installing a packer, shale trap, or another similar device, the fractured, cavernous zone or mine shaft may be filled with clean and disinfected gravel, or cement grout, and the abandoned well shall then be sealed by pressure grouting up to the ground surface.

(ii) Where the fractured, cavernous zone or mine shaft is less than twenty-five feet from the ground surface, the abandoned well shall be filled with cement grout with additives that promote bridging across the fractured, cavernous zone or mine shaft.

(b) The remainder of the abandoned well shall be sealed by pressure grouting.

(13) A dug or bucket augured abandoned well that is greater than twenty-four inches in diameter and less than twenty-five feet deep shall be sealed in accordance with the following:

(a) The static water level shall be measured and the abandoned well pumped dry, if possible.

(b) If the static water level is less than five feet below ground surface, then the following apply:

(i) The abandoned well shall be filled with clean clay or cement grout to the elevation of the static water level.

(ii) The liner shall be removed to the depth of the static water level, and the borehole shall be excavated radially six inches beyond the original borehole.

(iii) A one-foot layer of bentonite or cement grout shall be placed in the abandoned well at the elevation of the static water level. If the abandoned well is dry and bentonite is used, it shall be hydrated with five gallons of water per fifty pounds of bentonite.

(iv) The remaining borehole shall be filled with clean clay to ground surface.

(c) If the static water level is greater than five feet below ground surface, then the following apply:

(i) The abandoned well shall be filled with clean clay or cement grout to the elevation of the static water level.

(ii) At least the top three feet of casing, wall or liner material shall be removed and the borehole shall be excavated radially six inches beyond the original borehole.

(iii) A one-foot layer of bentonite or cement grout shall be placed in the abandoned well at the elevation of the static water level. If the abandoned well is dry and bentonite is used, it shall be hydrated with five gallons of water per fifty pounds of bentonite.

(iv) A layer of clean clay or cement grout shall be added above the grout until the level in the abandoned well is three feet below ground surface.

(v) Another one-foot thick layer of bentonite or cement grout shall be added at the level at which the casing, wall or liner material was removed. If the abandoned well is dry, the bentonite shall be hydrated with five gallons of water per fifty pounds of bentonite.

(14) A dug or bucket augured abandoned well that is greater than twenty-four inches in diameter and greater than twenty-five feet deep shall be sealed in accordance with either paragraph (C)(9) or (C)(10) of this rule.

(D) A copy of the well sealing report that is required by section [1521.05](#) of the Revised Code shall be submitted to the district office within thirty days of sealing a public water system well. The abandoned well location shall be clearly noted on a site map with reference to highways, streets, corporate boundaries and local physical landmarks.

[Comment: "Standard ANSI/NSF 60, Drinking Water Treatment Chemicals -Health Effects, December 11, 2009, Document Number NSF/ANSI 60-2009a." This rule incorporates this standard or specification by reference. A copy may be obtained from "NSF International, 789 N. Dixboro Road, P.O. Box 130140, Ann Arbor, MI 48105," (734) 769-8010, [www.nsf.org](http://www.nsf.org). The

standard is available for review at "Ohio EPA, Lazarus Government Center, 50 West Town Street, Suite 700, Columbus, OH, 43215."]

[Comment: The "State of Ohio Regulations and Technical Guidance For Sealing Unused Water Wells and Boreholes, 2015." This rule incorporates this guidance by reference. A copy may be obtained from "Ohio EPA, Lazarus Government Center, 50 West Town Street, Suite 700, Columbus, OH, 43215 ," (614) 644-2752, [www.epa.ohio.gov](http://www.epa.ohio.gov). The document is available for review at "Ohio EPA, Lazarus Government Center, 50 West Town Street, Suite 700, Columbus, OH, 43215."]

Effective: 6/13/2016

Five Year Review (FYR) Dates: 03/28/2016 and 06/13/2021

Promulgated Under: [119.03](#)

Statutory Authority: [6111.42](#), [6109.04](#)

Rule Amplifies: [6109.04](#)

Prior Effective Dates: 02/15/75, 05/01/03, 04/19/12

# **APPENDIX F**

## **3701-28-17 Procedures for the sealing and decommissioning of private water systems.**

(A) All private water systems that are not providing the source of water for human consumption, as defined in paragraph (CCC) of rule 3701-28-01 of the Administrative Code, shall either be sealed or decommissioned in accordance with this rule or maintained in strict compliance with all applicable requirements of this chapter.

(B) Upon completion of testing, a test hole shall either be permanently sealed or converted into a well with the minimum installation of well casing, grout, and cap, and the construction shall comply with all applicable requirements of this chapter.

(C) All dry holes that are not being used as a private water system shall be sealed in accordance with the provisions of this rule within ten days or may be converted to a geothermal system and meet the requirements of paragraph (B) of this rule.

(1) All uncased boreholes to be converted for geothermal use shall be protected with primary casing immediately upon determination that the borehole is a dry hole in order to prevent surface water infiltration.

(2) All dry holes or test holes to be converted for geothermal use shall be completed as a geothermal well within the remaining time period of the permit.

(D) When a replacement private water system, or a public water system is installed, or a connection is made to a public water system, any private water system that is not providing the primary source of water shall be sealed or decommissioned pursuant to the provisions of this rule within thirty days, unless the following conditions can be met:

(1) The private water system owner demonstrates to the satisfaction of the board of health that the private water system(s) will not cause or contribute to contamination of the ground water supply, present a safety hazard, or present a public health nuisance;

(2) Except for conditions cited in this rule, the private water system is, and will be maintained in compliance with this chapter;

(3) Demonstration of compliance for a well must include an ability to be tested, a water sample, the presence of an operational pumping system and one or more of the following:

(a) A well log;

(b) A downhole camera video survey;

(c) A dye test; or

(d) An assessment performed by a registered private water systems contractor or the board of health that the system meets the requirements of this chapter.

(4) A rainwater cistern or hauled water storage tank being kept to retain water as a nonpotable water source must:

(a) Include an operational pumping system;

(b) Provide no physical cross connection to another water system in accordance with paragraphs (F) and (G) of rule 3701-28-08 of the Administrative Code; and

(c) A rainwater cistern or hauled water storage tank being kept to retain water as a non-potable water source that meets the requirements of this paragraph is exempt from the requirements of rule 3701-28-15 of the Administrative Code for continuous disinfection and cyst filtration.

(5) Plastic tanks shall not be re-purposed as a room. A concrete rainwater cistern or hauled water storage tank to be retained as a complete structure shall be:

(a) Emptied of all accumulated water;

(b) Disconnected from all water collection systems;

(c) Disconnected from the distribution systems for the pressure tank, all water treatment, and plumbing and provide no physical cross connection in accordance with paragraphs (F) and (G) of rule 3701-28-08 of the Administrative Code; and

(d) Compliant with local building codes as follows:

(i) Be determined to be acceptable as a structure under local building codes; or

(ii) For a concrete rainwater cistern or hauled water storage tank beneath the foundation of a dwelling or building, be determined by local building codes sealing the rainwater cistern or hauled water storage tank in compliance with this rule could compromise the integrity of the foundation.

(6) All rainwater cisterns and hauled water storage tanks that are permanently out of service and not being kept by the property owner shall be:

(a) Disconnected from the distribution systems, the pressure tank, all water treatment, and plumbing and provide no physical cross connection in accordance with paragraphs (F) and (G) of rule 3701-28-08 of the Administrative Code;

(b) Disconnected from all water collection systems;

(c) Emptied of all accumulated water;

(d) Rendered non-watertight by removing at least one wall of the cistern or hauled water storage tank, all or in part, to prevent the accumulation of water;

(e) Removed when possible, if a plastic tank; and

(f) Completely filled with an inert solid material to prevent collapse.

(7) Springs and ponds no longer providing the source of water for a private water system shall be decommissioned by disconnecting distribution systems from the pressure tank, all water treatment, and plumbing and provide no physical cross connection in accordance with paragraphs (F) and (G) of rule 3701-28-08 of the Administrative Code.

(a) Springs and ponds retained by the property owner as a non-primary potable water source are exempt from the water treatment disinfection and filtration requirements of rule 3701-28-15 of the Administrative Code;

(b) Ponds retained by the property owner as a non-primary potable water source are exempt from the requirements of rule 3701-28-14 of the Administrative Code; and

(c) Springs retained by the property owner as a non-primary potable water source are exempt from the requirements of 3701-28-13 of the Administrative Code.

(E) Except when a private water system well is sealed, a completion form for decommissioning or retaining a private water system no longer providing water for human consumption as defined in paragraph (CCC) of rule 3701-28-01 of the Administrative Code shall be filed with the board of health.

(F) When the private water system is no longer a source of water for human consumption as defined in paragraph (CCC) of rule 3701-28-01 of the Administrative Code due to the connection to a public water supply, installation of a backflow prevention device containing a dual check valve assembly meeting the requirements of American society of sanitary engineering (ASSE) standards 1013 or 1015 is required.

(G) Except as provided in paragraph (I) of this rule, the owner of property on which a permanently out of service well or other private water system is located shall be responsible for the sealing of the well or decommissioning of the other private water system, unless a written contract between the property owner and a registered contractor provides otherwise.

(H) If the department determines that a registered contractor has improperly located or constructed a private water system, the water system contractor shall be responsible for sealing the well or decommissioning the other private water system or bringing the private water system into compliance.

(I) Information regarding the construction characteristics of the well or dry hole shall be obtained by the registered contractor intending to perform the work prior to the sealing of the well or dry hole. This information may be obtained from one or more of the following:

(1) The well log and drilling report filed in accordance with section 1521.05 of the Revised Code; or

(2) Surveys of the well or dry hole completed by using a borehole video camera, casing depth indicator, or caliper log.

(J) Sealing materials approved for use in rule 3701-28-09 of the Administrative Code shall be used to seal private water systems, test wells and dry holes.

(K) Except for shallow sand point wells where the entire casing is removed, all wells to be sealed, dry holes, or test wells shall be sealed in accordance with the following requirements, as applicable:

(1) To the extent possible, all obstructions should be removed from the well including pumps and related equipment, drop pipes, pit less adapters, suction lines, trash or other debris. Pumps that cannot be removed shall be pushed to the bottom of the well if possible, or left in place if it is not possible to push it to the bottom of the well.

(2) Well casing may be left in place, or may be removed, ripped or perforated to allow for sealing of the annular space. Unless permanently attached, all liner pipe should be removed from the well prior to placement of sealing materials. If the well casing or liner pipe is left in place, the private water systems contractor must ensure that grout materials are able to penetrate all annular spaces.

(3) If there is water flowing from around the outside of the well casing or there is gravel packing connecting two or more hydraulic zones the well shall be over drilled.

(4) Sealing materials authorized in rule 3701-28-09 of the Administrative Code shall be placed in the well in accordance with the following requirements:

(a) During the placement of grout slurry by pressure grouting methods, grout shall be placed from the bottom of the well or dry hole upwards in one continuous operation until cement or bentonite based grout of approximately the same density as the grout being pumped is coming out of the top of the well or dry hole.

(b) Cement and concrete grout slurries may be gravity poured into a dry hole where no water is present in the well or borehole.

(c) Where the borehole conditions, including depths at which water was encountered during the drilling process, and geologic formations are known via a well log or a down hole camera video recording, clean sand, gravel, or fire clay may be placed adjacent to screened or aquifer zone(s) greater than ten feet below the bottom of the casing and no closer than twenty-five feet below



ground surface. If the depth to the aquifer is unknown, then the entire well or borehole shall be filled with concrete, coarse grade or pelletized bentonite. Well sealing must ensure that no mixing of water between aquifers will occur.

(d) When dry pouring using coarse grade or pelletized bentonite the following requirements shall be met:

(i) Coarse grade or pelletized bentonite shall be poured slowly into the top of the well or dry hole to prevent bridging in the casing or borehole, in accordance with the following procedures:

(a) Coarse grade or pelletized bentonite shall be poured over a wire mesh screen to keep the fine bentonite powder from entering the well or dry hole.

(b) Screened coarse grade or pelletized bentonite shall be poured at a continuous rate no faster than the manufacturer's recommendation or two minutes per fifty pounds.

(c) The pouring process shall be halted intermittently to lower a weighted measuring tape into the well to determine the top of the sealing products and confirm that bridging has not occurred. A tamping device shall be used where possible to break any bridges that may form.

(d) Where the borehole or well is dry, the bentonite must be periodically hydrated with water in accordance with the manufacturer's requirements.

(ii) Fine bentonite particles that accumulate in the shipping container shall not be used.

(5) After the grout slurry sealing material has been placed into the well, dry hole or test hole the sealing material shall be assessed a minimum of twelve hours after placement to determine whether any settling has occurred. If settling has occurred, then additional grout shall be placed into the remaining void space.

(6) The total volume of sealing materials used to seal a well shall be not less than eighty per cent of the total volume of the space to be filled.

(7) Any remaining casing shall be cut off to a minimum depth of two feet below grade where possible. If a casing is terminated in a cement floor or structure, the casing may be cut off level to the grade of the cement floor or structure and finished with a level concrete pour.

(8) Well pits shall be removed by collapsing at least one wall, breaking up the floor, and removing or disconnecting all drains, and backfilling the remaining void space with native clay soils and graded to ensure water drains away.

(9) The remaining hole shall be filled with clean soil and graded to ensure that water drains away from the sealed well or dry hole.

(10) A well sealing report as required under section 1521.05 of the Revised Code shall be filed with the board of health, the department of natural resources division of geological survey, a copy provided to the well owner, and a copy retained by the registered contractor.

(L) Shallow sand point wells where the entire casing is removed, and the resulting formation collapse will restore the aquifer to its natural state shall be sealed in accordance with the following requirements:

(1) The entire length of casing shall be removed,

(2) A minimum of a one-foot radius around the location of the well casing shall be excavated to a minimum depth of two feet below grade and a one foot thick layer of coarse grade or pelletized bentonite or concrete grout shall be added. The bentonite shall be hydrated with five gallons of water per fifty pounds of bentonite if the excavation is dry.

(3) The remainder of the excavation shall be filled with clean clay or native soils as appropriate for the site and graded to ensure drainage away from the area.

(4) A well sealing report as required under section 1521.05 of the Revised Code shall be filed with the board of health, the department of natural resources division of geological survey, a copy provided to the well owner, and a copy retained by the registered contractor.

(M) In addition to the requirements of paragraphs (B) to (K) of this rule, wells drilled through multiple unconsolidated and consolidated aquifers that are not flowing at the surface shall be sealed in accordance with one of the following requirements, as applicable:

(1) The well shall be pressure grouted using concrete grout in accordance with paragraph (F) of rule 3701-28-09 of the Administrative Code or bentonite grout in accordance with paragraph (G) of rule 3701-28-09 of the Administrative Code.

(2) If the well is less than two hundred feet deep and greater than or equal to four inches in diameter or if the well is less than one hundred feet in depth and less than four inches in diameter, coarse grade bentonite may be poured into the well in accordance with paragraph (H) of rule 3701-28-09 of the Administrative Code.

(3) If detailed construction and geologic data is available, then clean sand, gravel, or fire clay may be placed adjacent to the aquifer zones with grout placed adjacent to the confining units. The well shall then be sealed from the top of the uppermost aquifer to the surface with cement grout in accordance with paragraph (F) of rule 3701-28-09 of the Administrative Code or bentonite grout in accordance with paragraph (G) of rule 3701-28-09 of the Administrative Code.

(N) For purposes of this rule "dug or bucket drilled well or dry hole" means a well consisting of a large diameter hole, deeper than it is wide, constructed into the ground, usually by hand, but if by mechanical means, by methods other than drilling, jetting, auguring or boring, and within which the side walls are supported by stone, brick, tiles or other similar materials. In addition to

the requirements of paragraphs (B) to (K) of this rule, dug wells shall be sealed in the following manner.

(1) All loose debris, drop pipes, pumps or other foreign materials shall be removed from the well as practical.

(2) Notwithstanding paragraph (K)(2) of this rule, the top three feet of casing, wall or liner material shall be removed and the area shall be excavated six inches beyond the original borehole;

(a) The entire depth of the dug well shall be filled with concrete, concrete mixes with aggregate sizes greater than medium sand up to 3/4-inch gravel may be used for the purposes of sealing a dug well; or,

(b) the dug well shall be sealed in the following manner:

(i) The well or hole shall be filled with gravel adjacent to the producing zone in the well. The remainder of the well shall be filled with concrete, coarse grade or pelletized bentonite, fire clay, clay, or cuttings to within fifteen feet of the natural ground surface.

(ii) A one foot thick layer of concrete, coarse grade or pelletized bentonite shall be placed from fourteen to fifteen feet below the natural ground surface.

(iii) A one foot thick layer of coarse grade or pelletized bentonite or concrete grout shall be added at the level at which the casing, wall, or liner material was removed and shall extend beyond the outside diameter of the well. The bentonite shall be hydrated with five gallons of water per fifty pounds of bentonite if the well is dry.

(iv) The remainder of the borehole shall be filled with clean clay or native soils as appropriate for the site and graded to ensure drainage away from the well.

(O) In addition to the requirements of paragraphs (B) to (K) of this rule, wells constructed using a bucket auger shall be sealed in the following manner:

(1) The well shall be sealed in accordance with paragraphs (B) to (K) of this rule to within fifteen feet of the natural ground surface.

(2) All well casing, liner pipe and gravel pack shall be removed to a depth of fifteen feet from the natural ground surface.

(3) The remaining borehole shall be filled with concrete, coarse grade or pelletized bentonite or a two foot layer of concrete, coarse grade or pelletized bentonite may be placed from thirteen to fifteen feet from the natural ground surface and the remainder of the borehole filled with clean clay or native fill material as appropriate for the site.

(4) The surface shall be graded to ensure drainage away from the well.

(P) In addition to the requirements of paragraphs (B) to (K) of this rule, wells that are flowing shall be sealed in accordance with the following requirements, as applicable:

(1) If possible, the casing shall be extended until the flow of water over the top of the casing stops.

(a) The well shall be pressure grouted using concrete or cement grout in accordance with paragraph (F) of rule 3701-28-09 of the Administrative Code; or

(b) When the flow can be controlled by extending the casing and if the well is less than two hundred feet deep, a sufficient weight of coarse grade or pelletized bentonite to permanently inhibit the natural flow may be poured into the well in accordance with paragraph (H) of rule 3701-28-09 of the Administrative Code.

(c) If the casing was extended and is intended to be cut off at the surface when the well has been sealed, then the concrete or cement shall be allowed to setup, or the coarse grade or pelletized bentonite allowed to fully hydrate prior to cutting off the casing extension.

(d) Bentonite slurries shall not be used for sealing flowing wells.

(2) If the hydrostatic head is too high to permit casing extension, one of the following requirements shall be met:

(a) An inflatable packer shall be installed at the top of the producing formation to stop or restrict the flow of water. The well shall then be pressure grouted using cement or concrete grout in accordance with paragraph (F) of rule 3701-28-09 of the Administrative Code through the packer from the bottom of the hole to the bottom of the packer. The packer shall then be deflated and pressure grouting shall continue to the surface;

(b) A shut-in device shall be installed at the top of the well to prevent flow.

A conductor pipe shall be inserted through the shut-in device and the well shall be pressure grouted using cement grout in accordance with paragraph (F) of rule 3701-28-09 of the Administrative Code from the bottom of the well to the ground surface;

(c) Clean, washed gravel may be poured into the well to reduce the flow of water to a point where an adequate weight of concrete or cement can still be placed to control the flow. The well shall then be pressure grouted using cement grout in accordance with paragraph (F) of rule 3701-28-09 of the Administrative Code from the top of the gravel to the ground surface; or

(d) Cement grout slurries shall be used. Additives to increase the density of the cement may be used to control the flow of water. Cement grout shall be placed in accordance with paragraph (F) of rule 3701-28-09 of the Administrative Code and appropriate placement techniques shall be used to ensure that separation of the cement does not occur during the grouting process.

(Q) In addition to the requirements of paragraphs (B) to (K) of this rule, wells drilled through fractured or cavernous formations where the size of the fracture or cavern is greater than one foot in thickness, or mine shafts shall be sealed in compliance with the following requirements:

(1) The depth and thickness of the fractured, cavernous zone or mine shaft shall be determined, if possible:

(a) Where the fractured, cavernous zone or mine shaft is greater than twenty-five feet from the ground surface, the borehole or well below the fractured zone shall be sealed in accordance with this rule and a plug consisting of a packer, shale basket, or other similar device shall be installed above the fractured or cavernous formation, with grout materials placed above the plug to the ground surface, or the intersection of the borehole or well and the fractured or cavernous zone shall either be filled with clean disinfected gravel, or left open, and the remainder of the borehole sealed to the ground surface.

(b) Where the fractured, cavernous zone or mine shaft is less than or equal to twenty-five feet from the ground surface, then the borehole or well shall be filled with cement grout with additives that promote bridging across the fractured, cavernous zone or mine shaft.

(2) The remainder of the well or borehole shall then be grouted in accordance with this chapter.

Replaces: 3701-28-17

Effective: 1/1/2020

Five Year Review (FYR) Dates: 09/20/2024

Promulgated Under: 119.03

Statutory Authority: 3701.344

Rule Amplifies: 3701.344

Prior Effective Dates: 01/01/1981, 01/01/2000, 04/01/2011

# APPENDIX G

## City of Girard Ordinance 6191-90

35--31 6/11/90

ORDINANCE NO. 6191-90

AN ORDINANCE FOR THE PURPOSE OF ENACTING CROSS-CONNECTION CONTROL FOR THE WATER SUPPLY OF THE CITY OF GIRARD, OHIO; PROVIDE AN EFFECTIVE MEANS OF PROTECTING THE CITY OF GIRARD WATER SYSTEM FROM THE BACKFLOW OF CONTAMINANTS THROUGH THE USE OF BACKFLOW PROTECTION DEVICES AND CHECK VALVES; AND DECLARING AN EMERGENCY.

WHEREAS, Section 6109.13 of the Ohio Revised Code requires the protection of a public water system from contamination through any connection whereby water from a private, auxiliary or emergency water system may enter the public water system; and

WHEREAS, Section 3745-85 of the Ohio Administrative Code requires the protection of the public water system from contamination due to backflow of contaminants through the water service connection; and

WHEREAS, the Ohio Environmental Protection Agency requires the maintenance of a continuing program of cross-connection control which will systematically and effectively prevent the contamination of all potable water systems; and

WHEREAS, in order to accomplish these goals, it is necessary to enact conditions which go beyond usual plumbing code requirements;

NOW, THEREFORE, BE IT ORDAINED, by the Thirty-Fifth Council of the City of Girard, Ohio, that:

SECTION ONE: That the Cross Control Program, at the discretion of the Director of Public Services shall include, but not necessarily be limited to:

(1) All new and replacement water service supplied from the water works mains of the City of Girard shall have a double check valve on the inside of the water meter setting.

(2) If, in the judgment of the Director of Public Service, an approved backflow prevention device is necessary for the safety of the public water system, the Director of Services shall give notice to the water consumer to install such an approved device immediately. The water consumer shall, at his own expense, install such an approved device at a location and in a manner approved by the Director of Public Services and shall have inspections and tests made of such approved devices as required.

(3) No person, firm or corporation shall establish, or permit to be established, or maintain, or permit to be maintained, any connection whereby a private, auxiliary or emergency water supply other than the public water supply of the City of Girard may enter the supply or distributing system of the City of Girard unless such private, auxiliary or emergency water supply shall have been approved by the Director of Public Services and by the Ohio Environmental Protection Agency.

(4) It shall be the duty of the Director of Public Services to cause surveys and investigations to be made of industrial and other properties served by the

public water supply where actual or potential hazards to the public water supply may exist. Such surveys and investigations shall be made a matter of public record and shall be repeated as often as the said Director shall deem necessary.

(5) The Director of Public Service, or his duly authorized representative, shall have the right to enter, at any reasonable time, any property served by a connection to the public water supply or distribution system of the City of Girard for the purpose of inspecting the piping system or systems thereof. On demand, the owner, lessees or occupants of any property so served shall furnish to the said Director any information that he may request regarding the piping system or systems or water use on such property. The refusal of such information, when demanded, shall, within the discretion of said Director be deemed evidence of the presence of improper connections as provided in this Section and Chapter.

(6) The Director of Water Utility Operations is hereby authorized and directed to discontinue, after reasonable notice to the occupant thereof the water service to any property wherein any connection in violation of the provisions of this Section or Chapter is known to exist, and to take such other precautionary contamination of the public water supply distribution mains. Water service to such property shall not be restored until such conditions shall have been eliminated or corrected in compliance with the provisions of this Section, Chapter, and any other applicable laws and regulations.

(7) That the Director of Public Service and Safety may adopt and enforce regulations in accord with this Section.

SECTION TWO: It is hereby determined that this Ordinance is an emergency measure necessary for the preservation of the public peace, health, safety, and general welfare and for the urgent benefit and protection of the City and its residents.

PASSED IN COUNCIL this 25th day of June, 1990.

Kathleen Hail  
CLERK OF COUNCIL

Joseph F. Christopher  
PRESIDENT OF COUNCIL

Filed with me and approved this 26th day of June, 1990.

William Leonard  
MAYOR

Jamieson/Kasiewicz

6/29/90

I Hereby Certify that this Ordinance was published in the Girard News on July 4<sup>th</sup> July 11, 1990

Kathleen Hail  
CLERK OF COUNCIL

# **APPENDIX H**

## **Instructions for Completing Annual Survey for Auxiliary Water Systems**

**Introduction** An approved backflow preventer shall be installed on each service connection serving any customer that has an auxiliary water system, unless the supplier of water determines, on a case by-case basis, that the installation of an approved backflow preventer on a service connection is not required. This decision must take into consideration several risks which are described below. The public water system is required to conduct or cause to be conducted an inspection at least every twelve months to certify that no connection or means of connection has been created between the public water system and the auxiliary water system.

“Auxiliary water system” means any water system on or available to the premises other than the public water system. The “Annual Survey for Auxiliary Water Systems” is intended to be used by public water systems or their representatives during an inspection for documentation purposes and to help evaluate if the alternative to installation of an approved backflow preventer is appropriate. This survey may be used for both the initial and annual surveys. The survey form consists of three sections to help ensure the collection of pertinent information. The instructions provide an explanation for each section of the survey. It is the responsibility of the public water system to make the final determination if the alternative to the installation of an approved backflow preventer will be permitted.

### **Completing the Survey**

The survey is designed to direct the surveyor in such a manner as to address all the risk factors that must be reviewed in accordance with Ohio Administrative Code (OAC) rule 3745-9504(C)(2)(a). These risk factors include, but are not limited to, the past history of cross connections being established or re-established on the premises, the ease or difficulty of connecting the auxiliary water system with the public water system on the premises, the presence or absence of contaminants on the adjacent real property or other risk factors.

The opening paragraph must be completed to include the water system name, date and address of the premises served by the public water system. You may want to include additional site information such as account number or other identifiers for tracking purposes.

**Potential Contaminant Source Inventory:** A table has been designed to determine if any potential contaminant sources, that represent a backflow hazard, are present on



the real property or premises. Real property refers to the land surrounding the premises and is owned or controlled by the consumer of water. "Premises" is defined in the Ohio Administrative Code as any building, structure, dwelling or area containing plumbing or piping supplied from a public water system. If any potential contaminant source, including an auxiliary water system, is connected to the public water system or otherwise contained on the premises, an appropriate

# APPENDIX I

## Approved Certified Plumbers & BF Testers by City of Girard

<b>Company</b>	<b>Last Name</b>	<b>First Name</b>	<b>Phone</b>	<b>Exp. Date For BF</b>
A TO Z PLUMBING & DRAIN	Bielecki Jr.	Andrew	(330)652-0511	
ADAM-EVE PLUMBING	Danko	Michael	(330)759-7037	
ADAM-EVE PLUMBING	Gorney	Elbert	(330)759-7037	
ALCON MECHANICAL INC	Cabuno	Joseph	(330)505-1704	
ALCON MECHANICAL INC	Kelly	J. Brent	(330)505-1704	
DIVERSIFIED COMFORT SERVICES INC	Fiumara	Dominic	(330)542-0382	
ENVIRONMENTAL CONTROLS FIRE PROTECTION	Gear	Parker	(330)334-0150	
ELLYSON PLUMBING	Kramer	Dave	(330)337-8795	
ELLYSON PLUMBING	Sweigard	Bart	(330)337-8795	
FIRE FOE CORP.	Nicholas	Michael	(330)759-9834	
FIRE FOE CORP.	Schwonek	Paul	(330)759-9834	
GIRARD HARDWARE	Thomas	George	(330)550-5266	
J.D. FARMER PLUMBING	Farmer III	James D.	(330)847-8740	
J.D. FARMER PLUMBING	Farmer	James L.	(330)847-8740	
J.P. PLUMBING INC.	Pezzano	James A.	(330)424-0054	
J.P. PLUMBING INC.	Davis	Matthew	(330)424-0054	
J.P. PLUMBING INC.	Kotanichek	Joshua	(330)424-0054	
JEFF THE PLUMBER, INC.	Wagner	Shane R.	(330)940-2600	
JEFF THE PLUMBER, INC.	Thompson	Ryan	(330)940-2600	
JEFF THE PLUMBER, INC.	Thompson	Jeffrey	(330)940-2600	
KOMAR PLUMBING CO.	Mochtyak	Daniel	(330)758-5073	

KOMAR PLUMBING CO.	Berger	Jerod	(330)758-5073	
LOU CARBONE PLUMBING	Carbone	Larry	(330)652-1441	
MID OHIO PLUMBING	Palmer	Ray	(740)375-4565	
MOODY PLUMBING	Gibson	Steve	(330)372-7669	
ODT PLUMBING	Thacker	Otis	(330)545-1457	
R.L. WINFIELD INC.	Winfield	Rae L.	(330)638-5295	
S.A. COMUNALE	Brown	Jerry D.	(800)776-71181	5/21/22
STEVENS PLUMBING	Stevens	Craig	(330)545-2788	
THACKER PLUMBING & HEATING	Estes	Harry	(330)544-0322	
THACKER PLUMBING & HEATING	Thacker Jr.	Richard	(330)544-0322	
THE NEFF COMPANY INC.	Mayesky	Scott	(330)533-5559	
THOMAS PLUMBING LLC	Thomas	George	(330)550-5266	
THORNTON & SON	Thornton	James	(330)793-9768	
TIMLIN PLUMBING & HEATING	Harkleroad	Edwin	(330)744-3000	
TIMLIN PLUMBING & HEATING	Jakovina	Russ	(330)744-3000	
TIMLIN PLUMBING & HEATING	Kurdziel	E. Steven	(330)744-3000	
TIMLIN PLUMBING & HEATING	Timlin	Michael	(330)744-3000	
YOUNGSTOWN FIRE AND SAFETY	Murdocco	Vince	(330)799-1301	10/15/22

\*\* Be sure to verify that license is valid and current \*\*

# APPENDIX J

## BIBLIOGRAPHY

American National Standards Institute. Air Gaps in Plumbing Systems. ANSI A112.1.2-1991. (1992)

American Water Works Association. AWWA Standard for Backflow Prevention Devices – Reduced Pressure Principle and Double Check Valve Types. AWWA C506-78 (Jan. 28, 1978).

American Water Works Association. Recommended Practice for Backflow Prevention and Cross-Connection Control. Manual of Water Supply Practices M-14. American Water Works Association (2004).

Angele, G. J., Sr., et al. Backflow Prevention and Cross-Connection Control. Manual M-14. American Water Works Association (1966). An extensive bibliography was added to AWWA Manual M-14 in 1970.

Angele, G. J., Sr. Cross-Connections and Backflow Prevention. Second Edition. American Water Works Association (1974).

Foundation for Cross-Connection Control and Hydraulic Research. Manual of Cross-Connection Control. Seventh Edition. University of Southern California (1985).

Foundation for Cross-Connection Control and Hydraulic Research. Manual of Cross-Connection Control. Ninth Edition. University of Southern California (1993).

Great Lakes-Upper Mississippi River Board of State Public Health Environmental Managers. Recommended Standards for Water Works. (1982). Health Education Services, P.O. Box 7283, Albany, N.Y. 12224.

Great Lakes-Upper Mississippi River Board of State Public Health Environmental Managers. Recommended Standards for Water Works. (2003). Health Education Services, P.O. Box 7283, Albany, N.Y. 12224.

Department of Health, Education and Welfare Publication 957. Water Supply and Plumbing Cross-Connections, Hazards in Household and Community Supply Systems. U.S. Government Printing Office, Washington D.C. (1963).

Ohio Department of Commerce, Industrial Compliance, Backflow Section. Backflow Prevention & Cross-Connection Control Manual, for the Education of Ohio Certified Backflow Prevention Technicians. Reynoldsburg, Ohio (2009)

Operator Training Committee of Ohio. Backflow Prevention Refresher Manual. Columbus, Ohio (March 2010).

Operator Training Committee of Ohio. Backflow Prevention Student Manual. Columbus, Ohio (March 2010).

National Fire Protection Association. NFPA 13: Standard for Installation of Sprinkler Systems, ed. 2010. Pages 13-38, 13-86, 13-91, 13-92, 13-236, 13-290.

National Fire Protection Association. NFPA 20: Standard for Installation of Stationary Pumps for Fire Protection, ed. 2010. Pages

National Fire Protection Association. NFPA 25: Standard for Inspection, Testing and Maintenance of Water-Based Fire Protection Systems, ed. 2008. Pages 25-8, 25-12, 25-45, 25-51.

U.S. Environmental Protection Agency Office of Water Programs, Water Supply Division. Cross-Connection Control Manual. U.S. Government Printing Office, Washington D.C. (1974).

U.S. Environmental Protection Agency Office of Water Programs, Office of Ground Water and Drinking Water. Cross-Connection Control Manual. EPA 816-R-03-002. U.S. Government Printing Office, Washington D.C. (2003).